

SERVICE MANUAL
(Machine Code: C625)

IMPORTANT SAFETY NOTICES

PREVENTION OF PHYSICAL INJURY

1. Before disassembling or assembling parts of the printer and peripherals, make sure that the power cord is unplugged.
2. The wall outlet should be near the printer and easily accessible.
3. If any adjustment or operation check has to be made with exterior covers off or open while the main switch is turned on, keep hands away from electrified or mechanically driven components.

HEALTH SAFETY CONDITIONS

1. If you get ink in your eyes by accident, try to remove it with eye drops or flush with water as first aid. If unsuccessful, get medical attention.
2. If you ingest ink by accident, induce vomiting by sticking a finger down your throat or by giving soapy or strong salty water to drink.

OBSERVANCE OF ELECTRICAL SAFETY STANDARDS

1. The printer and its peripherals must be installed and maintained by a customer service representative who has completed the training course on those models.

SAFETY AND ECOLOGICAL NOTES FOR DISPOSAL

1. Dispose of replaced parts in accordance with local regulations.
2. Used ink and masters should be disposed of in an environmentally safe manner and in accordance with local regulations.

Symbols

This manual uses several symbols. The meaning of those symbols are as follows:







	See or Refer to
	Core tech manual
	Clip ring
	E-ring
	Screw
	Connector
SEF	Short edge feeding
LEF	Long Edge feeding

TABLE OF CONTENTS

1. INSTALLATION.....	1-1
1.1 INSTALLATION REQUIREMENTS.....	1-1
1.1.1 OPTIMUM ENVIRONMENTAL CONDITION	1-1
1.1.2 ENVIRONMENTS TO AVOID	1-1
1.1.3 POWER CONNECTION	1-1
1.1.4 MACHINE ACCESS.....	1-2
1.2 INSTALLATION PROCEDURE	1-3
1.2.1 ACCESSORY CHECK.....	1-3
1.2.2 INSTALLATION PROCEDURE.....	1-5
LCOT	1-5
LCIT	1-7
2. PREVENTIVE MAINTENANCE	2-1
2.1 MAINTENANCE TABLE	2-1
3. REPLACEMENT AND ADJUSTMENT	3-1
3.1 GENERAL CAUTION.....	3-1
3.2 LCIT	3-1
3.2.1 COVERS.....	3-1
Front covers	3-1
Rear covers.....	3-1
Top cover	3-1
Intermediate upper cover	3-2
Intermediate under cover	3-2
3.2.2 BOARDS.....	3-3
MPU	3-3
PSU.....	3-3
3.2.3 FIRMWARE UPDATE.....	3-4
3.2.4 FEED TABLE	3-5
Paper end sensor.....	3-5
Paper length sensor	3-5
Paper table upper limit sensor.....	3-6
Paper table height sensor	3-6
Paper table lower limit sensor	3-6
Paper table lifting switch	3-7
Paper table lowering switch.....	3-7
Feed table drive harness.....	3-7
3.2.4 PAPER FEED	3-8
Paper feed roller.....	3-8
Paper separation roller.....	3-8
Friction pad	3-8
Paper feed roller unit.....	3-9
Paper feed bushing	3-10
Paper separation bushing	3-10
Paper separation pressure adjustment	3-10

3.2.5	INTERMEDIATE FEED SECTION.....	3-11
	Upper feed roller spring.....	3-11
	Intermediate upper feed roller.....	3-12
	Intermediate under feed roller.....	3-13
	Intermediate paper feed sensors.....	3-13
	Paper end solenoid.....	3-14
	Paper length solenoid.....	3-14
	Brake guide.....	3-14
3.2.6	DRIVE.....	3-15
	Paper feed motor.....	3-15
	Paper feed motor belt.....	3-15
	Paper table motor.....	3-16
	Paper table motor belt.....	3-16
	Paper table drive belt.....	3-17
	Intermediate paper feed motors.....	3-18
	Intermediate paper feed motor belt.....	3-18
3.2.7	SIDE FENCE.....	3-19
	Side fence adjustment belt (top and bottom).....	3-19
	Paper width detection board.....	3-21
3.3	LCOT.....	3-22
3.3.1	COVERS.....	3-22
	Front cover.....	3-22
	Rear cover.....	3-22
	Top cover.....	3-22
3.3.2	BOARD.....	3-23
	MPU.....	3-23
3.3.3	FIRMWARE UPDATE.....	3-24
3.3.4	DELIVERY TABLE.....	3-25
	Paper table upper and lower limit sensors.....	3-25
	Paper table lifting and lowering switch.....	3-25
3.3.5	END FENCE.....	3-26
	End plate arm.....	3-26
	End plate release sensor.....	3-26
3.3.6	DRIVE.....	3-26
	Paper table motor.....	3-26
	Paper table motor belt.....	3-26
	Paper table drive belt.....	3-26
3.3.7	SIDE FENCE.....	3-27
	Side fence adjustment belt (top and bottom).....	3-27
	Paper delivery side plate.....	3-27
	Side fence guide.....	3-27
	Paper amount sensor.....	3-28
4.	TROUBLESHOOTING.....	4-1
4.1	ERROR INDICATORS.....	4-1
	4.1.1 LED.....	4-1
	4.1.2 SERVICE CALL.....	4-1
4.2	ELECTRICAL COMPONENT DEFECTS.....	4-2
	4.2.1 LCIT.....	4-2

4.2.2	LCOT	4-3
4.3	CHECK POINTS FOR PROBLEMS	4-5
4.3.1	WRONG PAPER SIZE DETECTION	4-5
4.3.2	SHIFTED PRINTING POSITION	4-7
4.3.3	PAPER NON-FEED	4-8
	PAPER DELIVERY ALIGNMENT	4-9
5.	SERVICE TABLES	5-1
5.1	SERVICE PROGRAM MODE	5-1
5.1.1	TO ENTER AND EXIT THE SP MODE - LCIT	5-1
	Input check	5-2
	Output check	5-4
	TO ENTER AND EXIT THE SP MODE - LCOT	5-6
	Input check	5-7
	Output check	5-8
	Paper table motor	5-8
	Adjustment	5-9
6.	DETAILED SECTION DESCRIPTIONS	6-1
6.1	MECHANISM OVERVIEW	6-1
6.1.1	EXTERIOR – LCIT	6-1
6.1.2	EXTERIOR - LCOT	6-2
6.1.3	ELECTRICAL COMPONENT LAYOUT	6-3
	Boards	6-4
	Motors	6-4
	Switches	6-4
	Solenoids	6-4
	Sensors	6-5
	Others	6-5
6.2	PAPER FEED TABLE ON THE DUPLICATOR	6-6
	Mechanism	6-6
6.3	PAPER FEED TABLE	6-7
6.3.1	PAPER SIZE AND PAPER END DETECTION	6-7
6.3.2	PAPER SIDE FENCE MECHANISM – LCIT	6-8
	Mechanism	6-8
6.3.3	PAPER FEED TABLE DRIVE	6-9
	Mechanism	6-9
6.3.4	PAPER FEED TABLE HEIGHT CONTROL	6-10
6.4	PAPER FEED MECHANISM	6-11
6.4.1	PAPER FEED ROLLER MECHANISM	6-11
	Mechanism	6-11
6.4.2	PAPER FEED AND SEPARATION PRESSURE MECHANISM	6-12
6.5	INTERMEDIATE FEED SECTION	6-13
6.5.1	OVERVIEW	6-13
	Mechanism	6-13
	Procedure	6-13
6.5.2	TRANSFERRING PAPER DETECTION INFORMATION	6-14
	Mechanism	6-14
6.5.3	INTERMEDIATE FEED MECHANISM	6-15

6.6 PAPER DELIVERY TABLE.....	6-16
6.6.1 PAPER DELIVERY TABLE HEIGHT	6-16
Paper Delivery Table Drive Mechanism	6-16
6.6.2 PAPER AMOUNT DETECTION.....	6-16
Mechanism.....	6-16
6.6.3 PAPER SIDE FENCE MECHANISM - LCOT.....	6-16
6.7 TIMING CHART.....	6-17
6.7.1 PAPER FEED - LCIT	6-17
Type 1	6-18
6.7.2 PAPER DELIVERY TABLE.....	6-19
7. POINT TO POINT DIAGRAM	7-1
7.1 LCIT (1).....	7-1
LCIT (2)	7-2
7.2 LCOT	7-3
SPECIFICATIONS.....	SPEC-1
1. GENERAL SPECIFICATIONS.....	SPEC-1

1. INSTALLATION

1.1 INSTALLATION REQUIREMENTS

Carefully set the installation location. Environment conditions can change machine performance

1.1.1 OPTIMUM ENVIRONMENTAL CONDITION

1. Temperature —10 C to 30 C (50 to 86 F)
2. Humidity —20 % to 90 % RH
3. Install the machine on a strong and level bottom. The machine must be level in 5 mm (0.2 inch) front to rear and left to right.

1.1.2 ENVIRONMENTS TO AVOID

1. Locations that get direct sunlight or strong light (more than 1,500 lux).
2. Areas that contain dust.
3. Areas with gases that can cause corrosion.
4. Locations that get cool air from an air-conditioner or reflected heat from a space heater. (Sudden temperature changes from low to high, or from high to low, can cause condensation in the machine.)

1.1.3 POWER CONNECTION

1. Correctly connect the power cord to a power source.
2. Make sure that the wall outlet is near the machine and has easy access.
3. Make sure that the plug is tightly in the outlet.
4. Prevent multi-wiring.
5. Do not pinch the power cord.
6. Voltage must not fluctuate more than 10%.

1.1.4 MACHINE ACCESS

Put the machine near a power source. Give clearance as shown in this drawing.

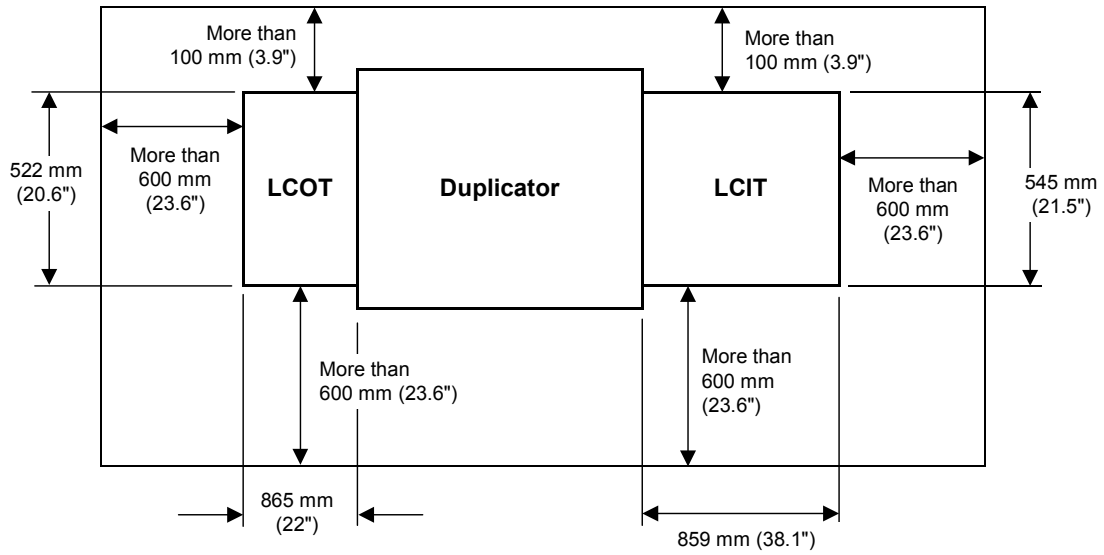

C625I910.WMF

1.2 INSTALLATION PROCEDURE

1.2.1 ACCESSORY CHECK

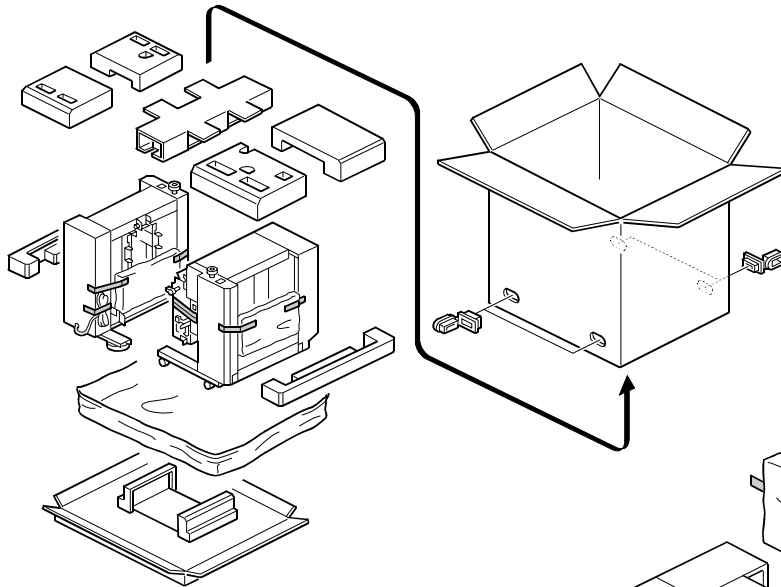

C625101.WMF

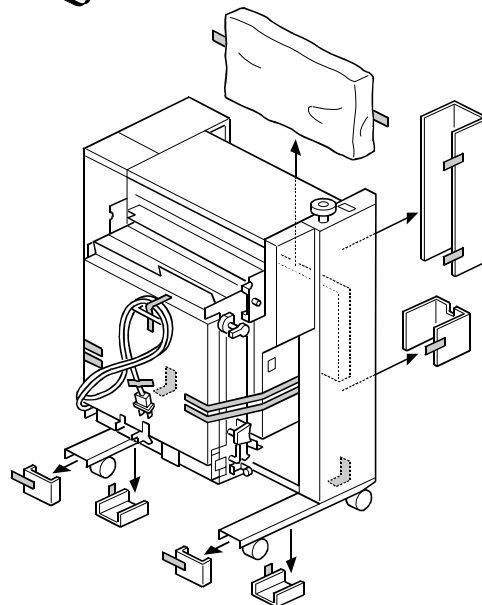

C625107.WMF

1. Remove the contents from the box.

<p>⚠ CAUTION To prevent injury, do not connect the power plug to the machine until the instructions tell you to do it.</p>
--

2. Remove all wrapping from the machine.
3. Remove the filament tape and string that attaches the covers and units.

4. Make sure that you have all these accessories:

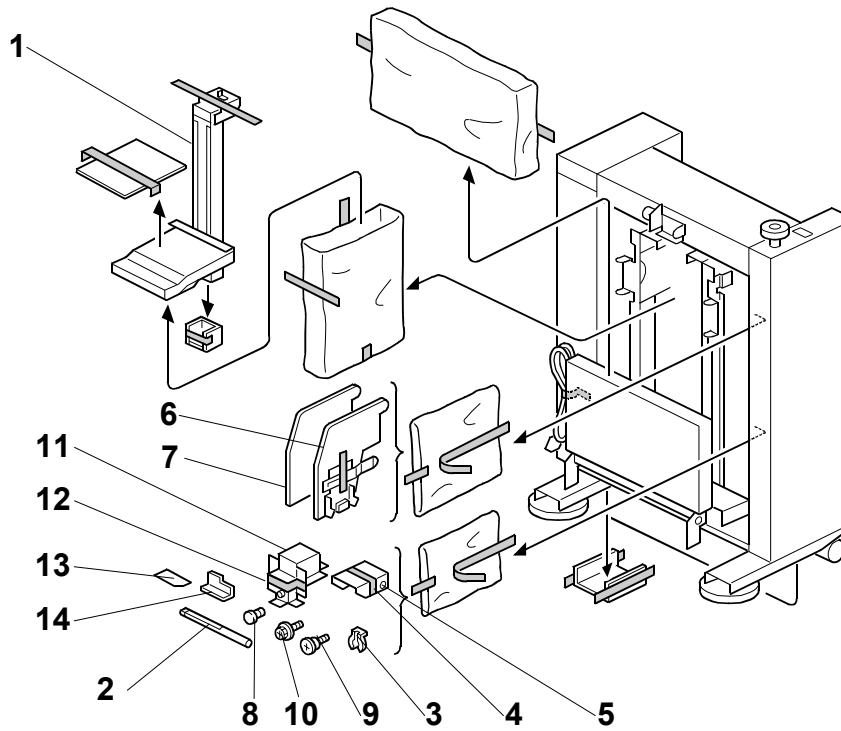

C625106.WMF

Description	Q'ty
1. End plate arm	1
2. End plate shaft	1
3. Snap ring (To hold the side fence and end fence shaft)	3
4. Front connection bracket	1
5. Rear connection bracket	1
6. Paper delivery side plate – front.....	1
7. Paper delivery side plate – rear.....	1
8. Side plate shaft.....	2
9. Stepped screws (To install the connection brackets).....	2
10. Tapping screws (To attach the duplicator to the LCOT)	2
11. Rear bracket (For models C229, C233, C235, C593).....	1
12. Front bracket (For models C229, C233, C235, C593)	1
13. Long guide (For model C229, C233, C239)	1
14. Side plate guide (For models C229, C233, C235, C239, C244)	1

1.2.2 INSTALLATION PROCEDURE

LCOT

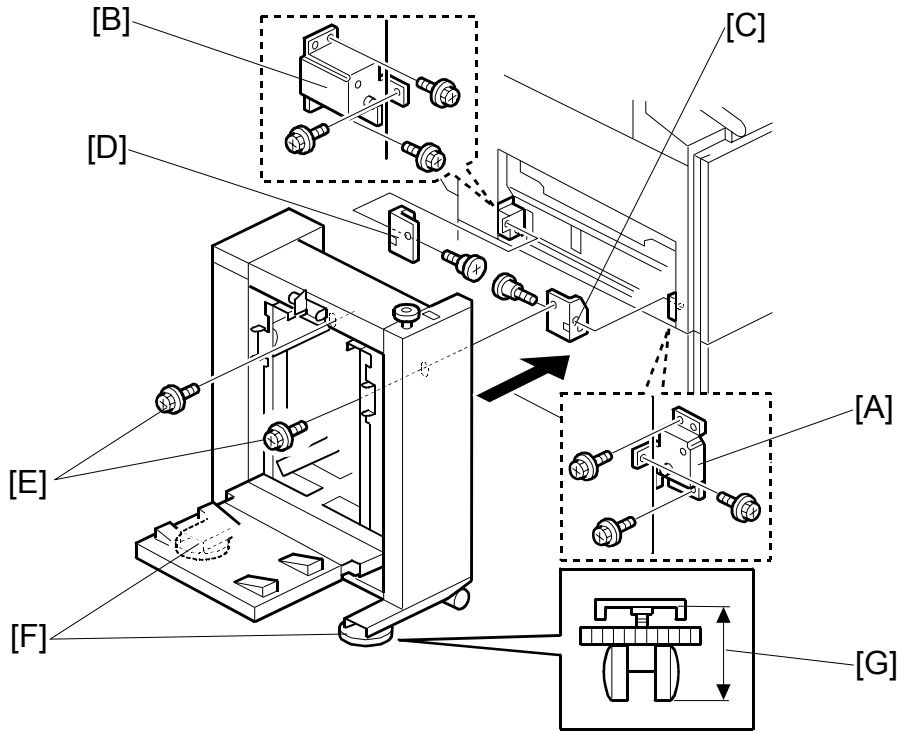

C625I05.WMF

1. – **Model C229/C233/C235/ C593 only** –
Replace the front connection bracket [A] and the rear connection bracket [B].
2. Attach the front connection bracket [C] and the rear connection bracket [D] with the stepped screws (in the accessory bag).
3. Install the LCOT.
4. Attach the LCOT with two tapping screws [E] (in the accessory bag).
NOTE: Adjust the height with the knobs [F] until:
 - a) The gap [G] between the stay and the floor is 65mm
 - b) The LCOT is parallel to the machine.

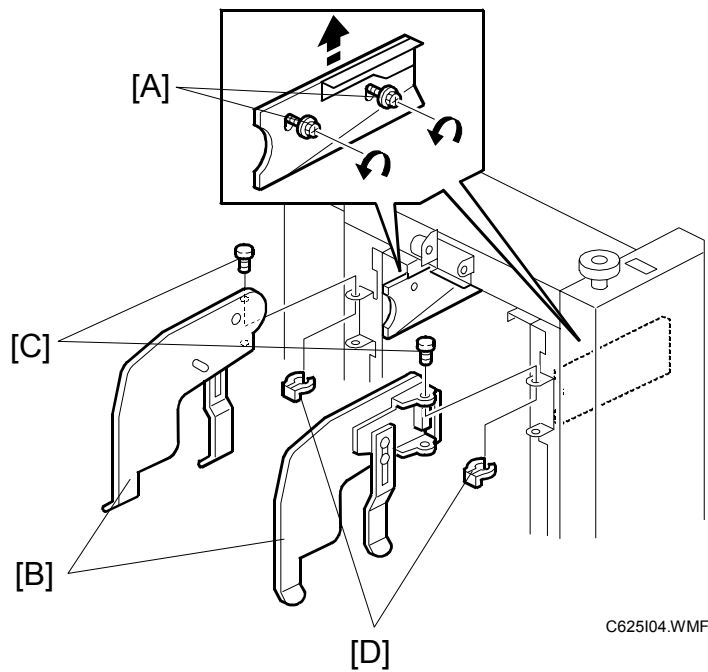

5. – **Model C593 only** –

- Loosen two screws [A] on each side fence guide. Then move the side fence guide up. Then tighten the screws again.
- 6. Attach the paper-delivery side plates [B].
- 7. Install the side plate shafts [C]. Then install the snap rings [D].

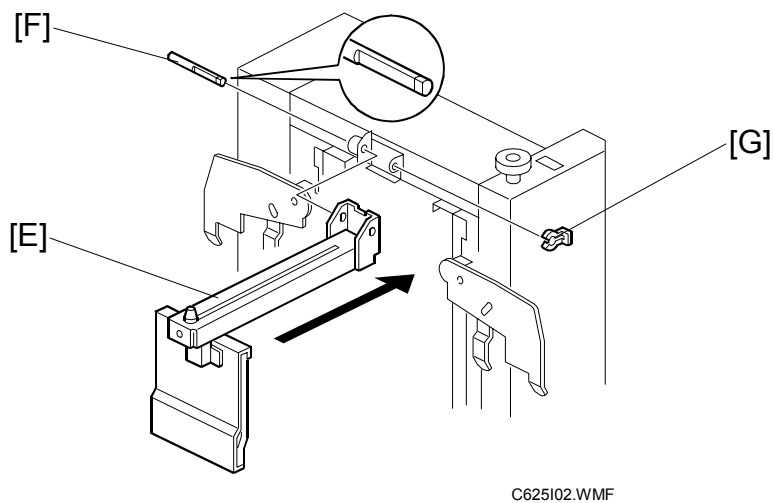

- 8. Attach the end plate arm [E].
- 9. Install the end fence shaft [F] from the rear side of the machine (the beveled end must go in first). Then install the snap rings [G].

LCIT

1. Open the paper feed tray of the machine.

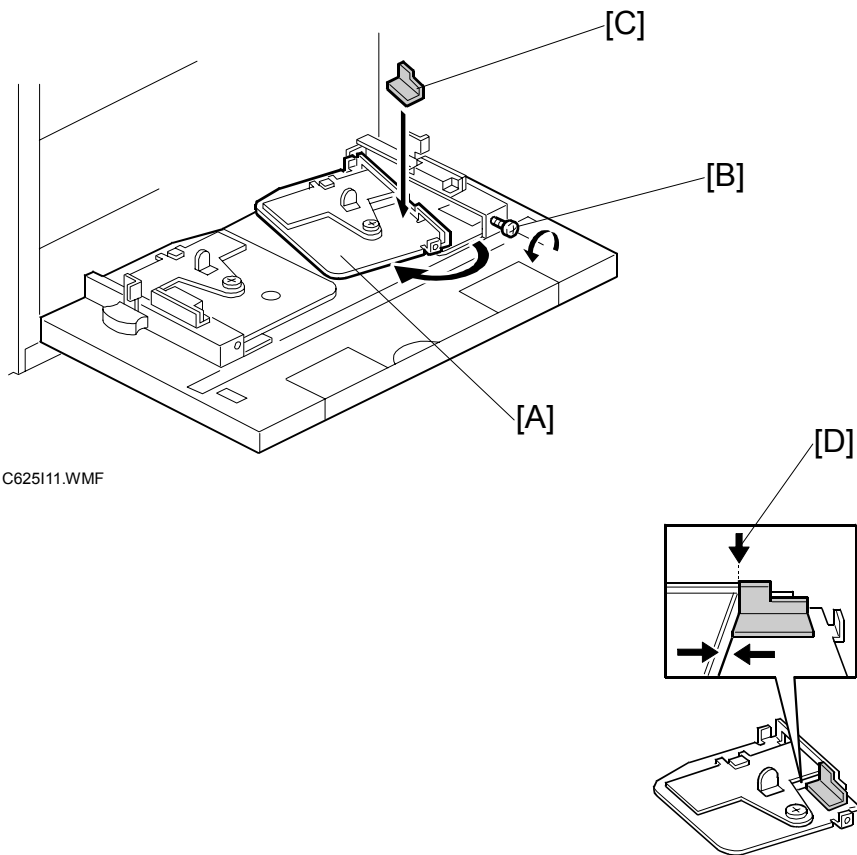

C625I11.WMF

C625I912.WMF

2. – **Model C229/C233/C235/C239 /C244 only** –
At the rear side of the rear paper-feed side plate [A], remove the screw [B].
Then attach the side plate guide [C].

NOTE: The side plate guide [C] should be attached to line [D]. (☛ 6.2)

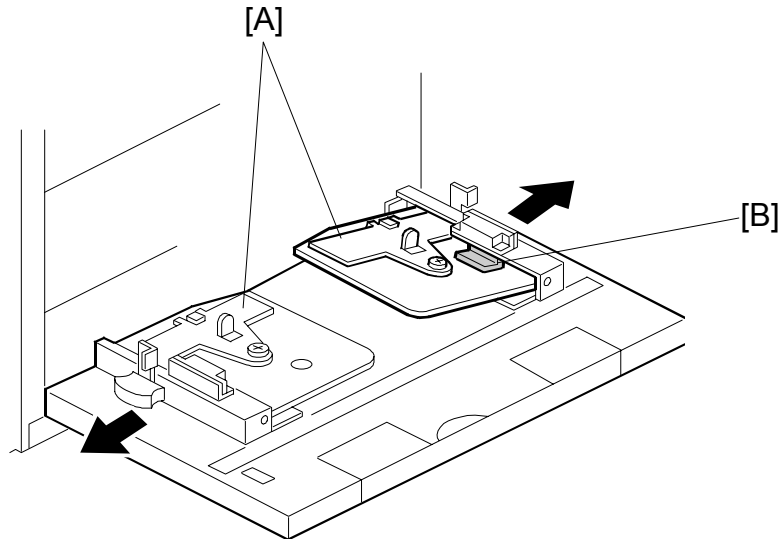

C625I909.WMF

3. Move the paper-feed side plates [A] of the paper feed tray of the duplicator to the widest position.

NOTE: The paper-feed side plates [A] can be above the tray surface because of the side plate guide [B], even when they are folded. Do not push them down with a large force.

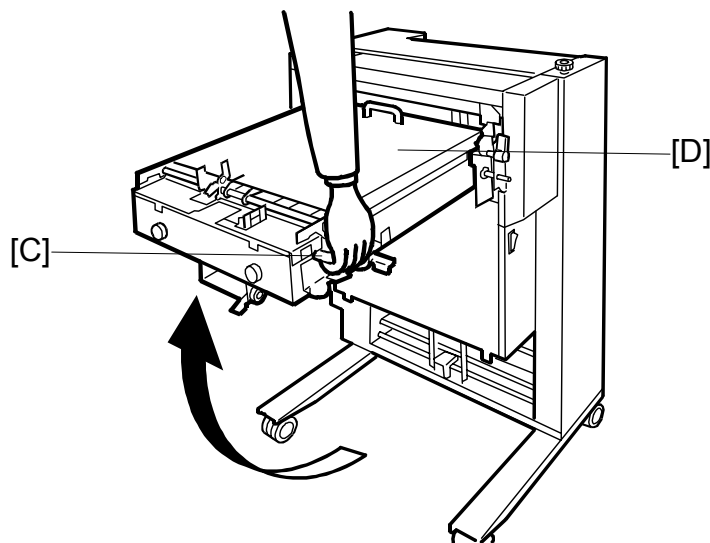

C625I905.WMF

4. Hold the handle [C] and unfold the intermediate feed section [D] of the LCIT.

NOTE: Do not release the handle [C], or it will not hold the position.

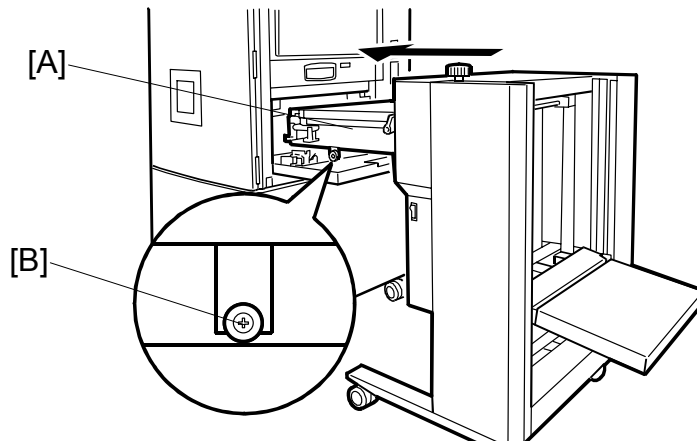

C6251906.WMF

- Lift the end of the intermediate feed section [A] and put it down on the feed tray. Then put the wheel of the support bar [B] on the paper feed tray.

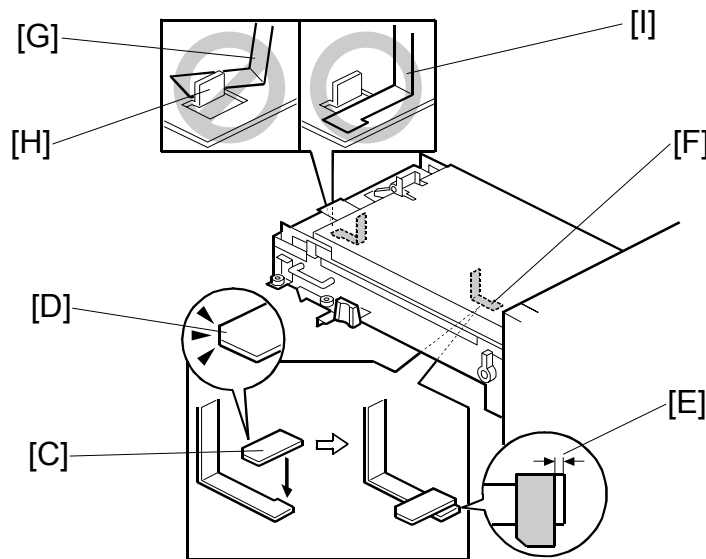

C625108.WMF

6. – **Model C229/C233/C239 only** –

Attach the long guide [C] below the intermediate feed section.

NOTE: The position of the beveled corner [D] must be as shown above.

The gap [E] should be 2 to 3 mm.

The paper length guide [F] is under the intermediate feed section (between the intermediate feed section and the paper feed tray of the machine).

- Check if the paper end mylar [G] is positioned behind the pawl [H]. If yes, Move the mylar back to the correct position [I].
(☛ 4.3.1)

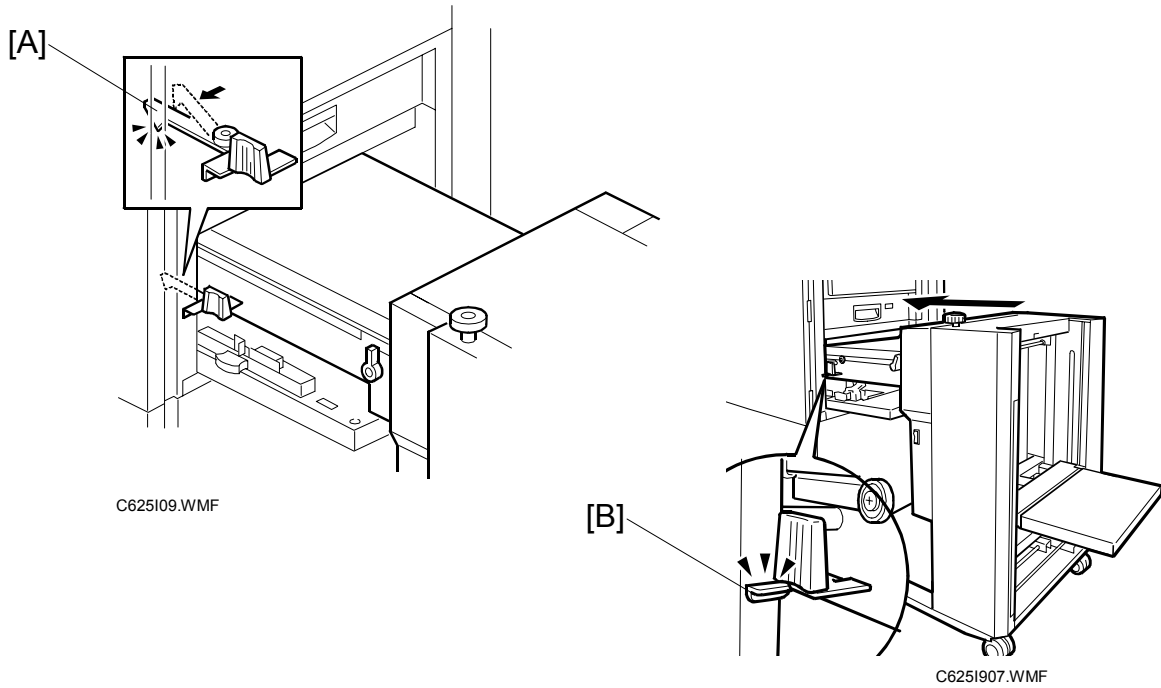

8. Push the LCIT into the machine until it makes a click [A].
NOTE: Make sure that the metal projections [B] on the two sides touch the machine. If there is a gap, push until there is no gap.

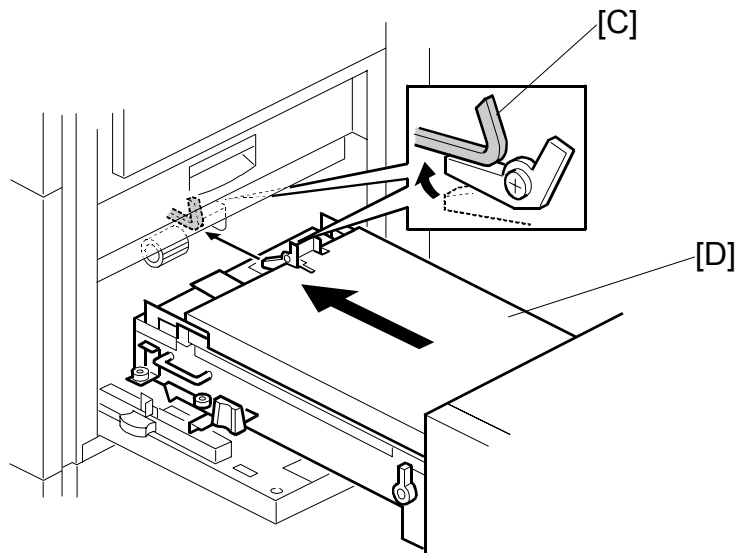

CAUTION: The LCIT must be installed straight. If not, the lever [C] will hit the intermediate feed section [D].

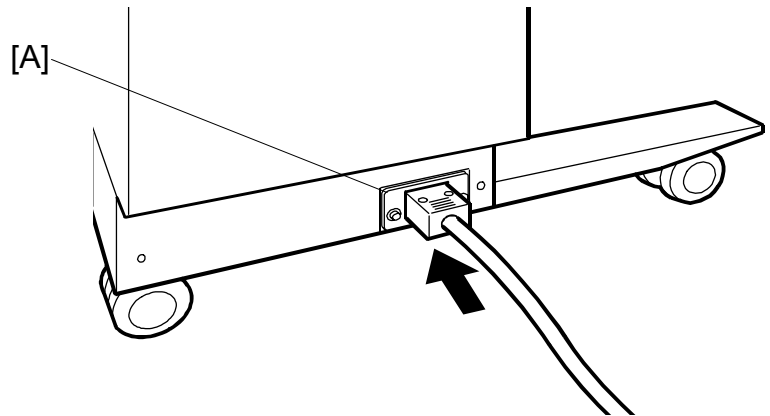

C6251908.WMF

9. Connect the LCOT connection cord into the socket at the bottom of the rear of the LCIT [A].
10. Check the parts in this table after installation.

Type	Front and Rear bracket	Side plate guide	Long guide	Tapping screws x 2
C229	Use	Use	Use	Use
C233	Use	Use	Use	Use
C235	Use	Use	Use	Use
C239	No	Use	No	No
C244	No	Use	No	No
C593	Use	No	No	Use

11. Connect the LCIT power cord into the wall outlet.
12. Make a test print
NOTE: Adjust the side fence of the duplicator to match the paper size (●4.3.1).

2. PREVENTIVE MAINTENANCE

2.1 MAINTENANCE TABLE

The following items must be maintained periodically.

Symbol key: C: Clean, R: Replace, L: Lubricate, A: Adjust

WARNING

Turn off the main power switch and disconnect the machine before you do any procedure in this section.

Preventive
Maintenance

ITEM	INTERVAL	EVERY 600K	EVERY 1200K	EVERY 2400K	WHEN VISIT	NOTE
LCIT						
Tray section						
Paper feed tray					C	Damp Cloth
Paper feed side fence					C	Damp Cloth
Paper end sensor					C	Dry Cloth
Paper length sensor					C	Dry Cloth
Paper feed section						
Paper feed roller		C	R			Damp Cloth (Alcohol)
Paper separation roller		C	R			Damp Cloth (Alcohol)
Friction pad		C	R			Damp Cloth (Alcohol)
Paper feed bushing [1]					L	Motor Oil
Paper separation bushing [2]					L	Motor Oil
Paper feed pressure lever unit [3]					L	Grease (Albania No. 2, made by Shell)
Intermediate feed section						
Upper feed roller					C	Damp Cloth (Alcohol)
Lower feed roller			R		C	Damp Cloth (Alcohol)
Intermediate paper sensor					C	Dry Cloth
Intermediate feed guide board			C			Damp Cloth (Alcohol)
Brake guide			R			
Drive unit						
Gears [5] (paper table drive unit)		L				Grease (Mobile temp 78)

ITEM	INTERVAL	EVERY 600K	EVERY 1200K	EVERY 2400K	WHEN VISIT	NOTE
LCOT						
Tray section						
Paper delivery tray					C	Damp Cloth
Paper delivery side fence					C	Damp Cloth
End plate					C	Damp Cloth
Paper delivery side wing					C	Damp Cloth
Paper delivery side guide					C	Damp Cloth
Drive Unit						
Gears [5] (paper table drive unit)		L				Grease (Mobile temp 78)

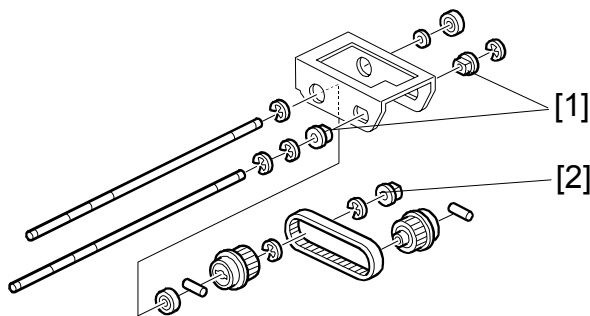

C625R31.WMF

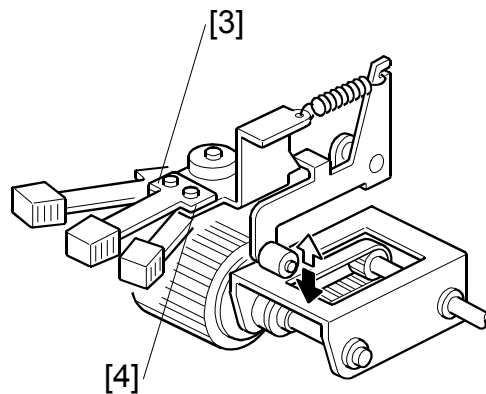

C625D909.WMF

Apply grease between the lever [3] and stay [4]

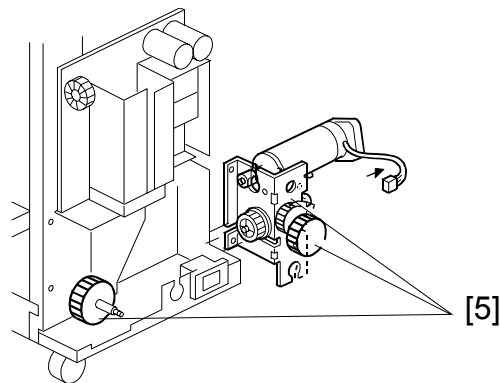

C625P901.WMF

3. REPLACEMENT AND ADJUSTMENT

3.1 GENERAL CAUTION

⚠ CAUTION

Turn off the main power switch and disconnect the machine before you try any of the procedures in this section.

3.2 LCIT

3.2.1 COVERS

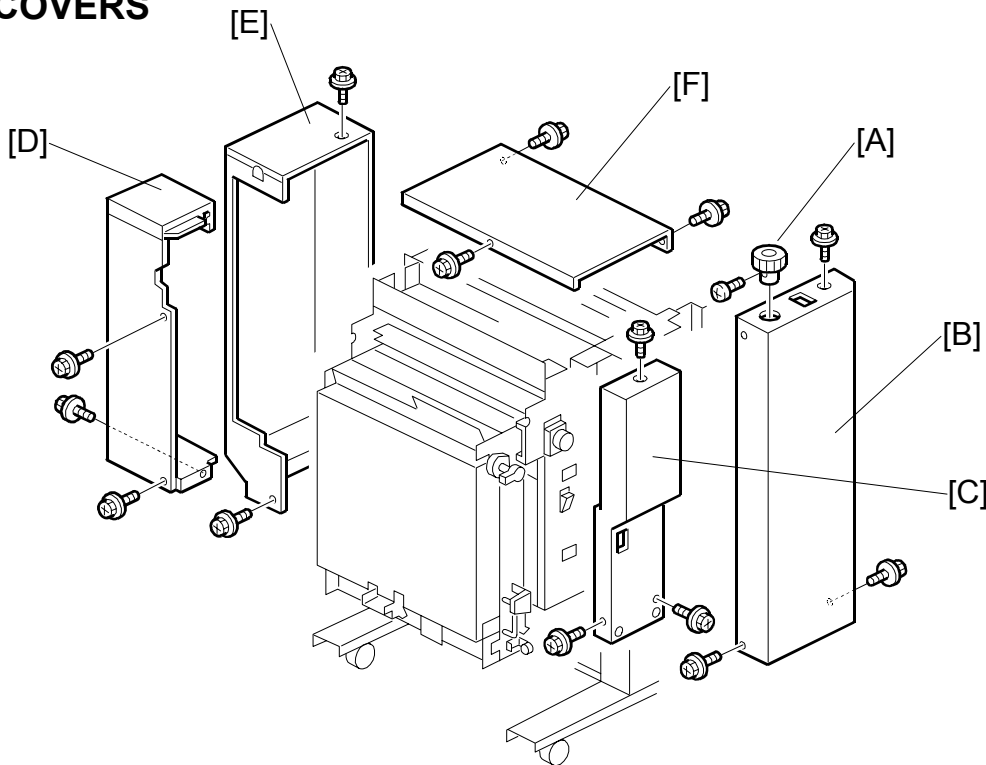

Replacement
Adjustment

C625R21.WMF

Front covers

[A]: Side fence adjustment knob (⚙ x 1)

[B]: Front cover (⚙ x 3)

[C]: Front side cover (⚙ x 3)

Rear covers

[D]: Rear side cover (⚙ x 3)

[E]: Rear cover (⚙ x 3)

Top cover

[F]: LCIT top cover (⚙ x 3)

Intermediate upper cover

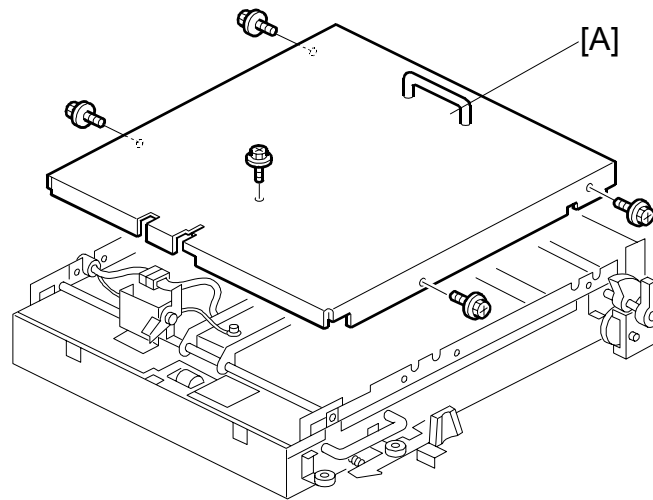

C625R03.WMF

[A]: Intermediate upper cover (🔩 x 5)

Intermediate under cover

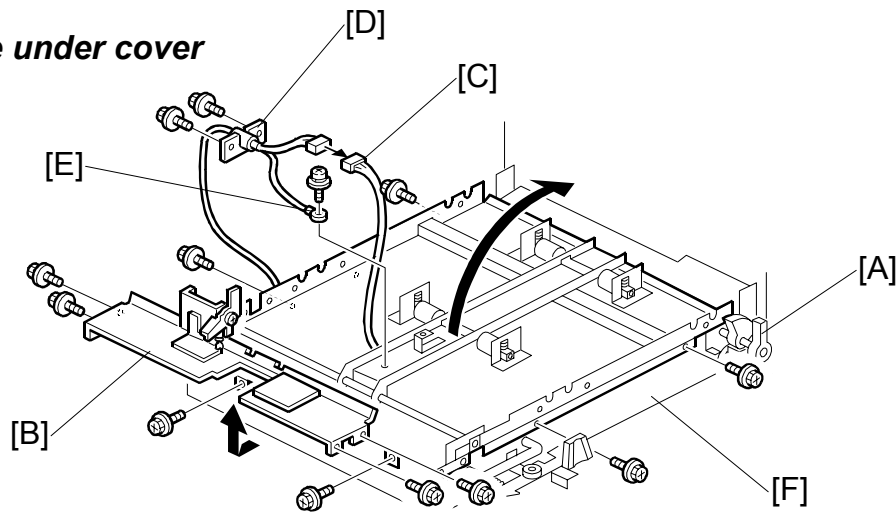

C625R914.WMF

Intermediate upper cover (☞ 3.2.1)

[A]: Release the upper cover release lever

[B]: Brake guide bracket (🔩 x 4, 📏 x 1)

CAUTION: Be careful when you remove the brake guide bracket. There are brake guides below the bracket [B].

[C]: Harness (📏 x 1)

[D]: Bracket (🔩 x 2)

[E]: Ground wire (🔩 x 1)

[F]: Intermediate under cover (🔩 x 6)

3.2.2 BOARDS

MPU

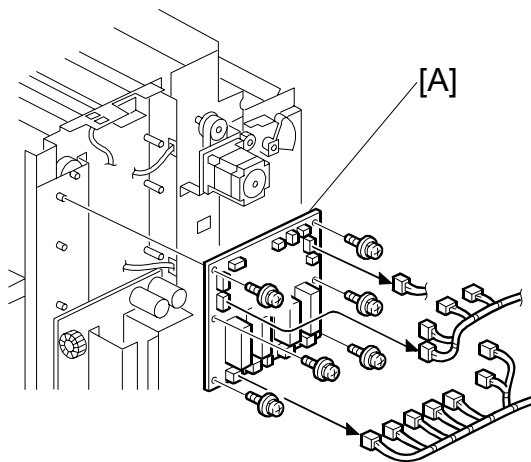

C625R22.WMF

Replacement
Adjustment

Rear cover (☛ 3.2.1)

[A]: MPU (⚙ x 6, 📡 x 13)

- NOTE:** 1) Check the dip switch settings on the old MPU, and make the dip switch settings the same on the new MPU.
2) Make sure that the EPROM on the MPU contains the correct firmware.

PSU

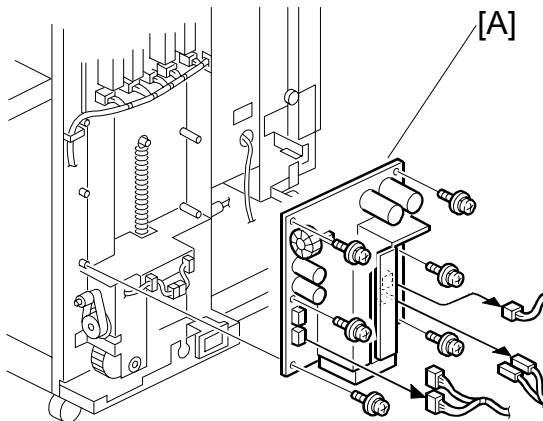

C625R23.WMF

- Rear cover (☛ 3.2.1)
- [A]: PSU (⚙ x 6, 📡 x 5)

3.2.3 FIRMWARE UPDATE

To upgrade the firmware in the EPROM on the MPU – LCIT, replace the EPROM.

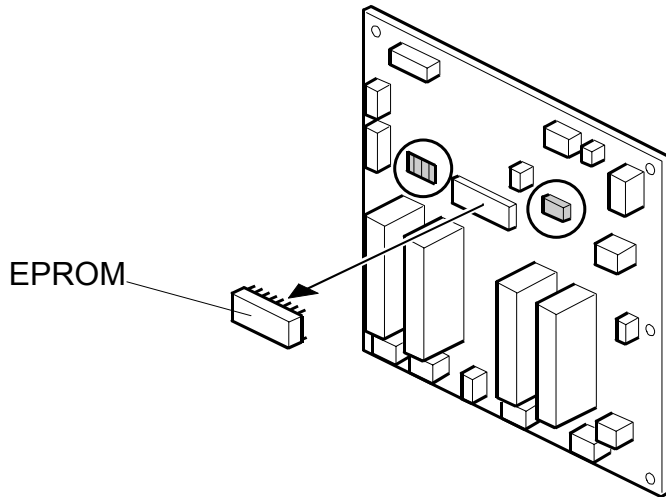

C625R910.WMF

NOTE: Before you upgrade the firmware, check the current suffix version on the EPROM label.

1. Turn off the main switch and disconnect the power plug.
2. Remove the rear cover.
3. Replace the EPROM on the MPU - LCIT.
4. Check if the machine works correctly after you replace the EPROM.

3.2.4 FEED TABLE

Paper end sensor

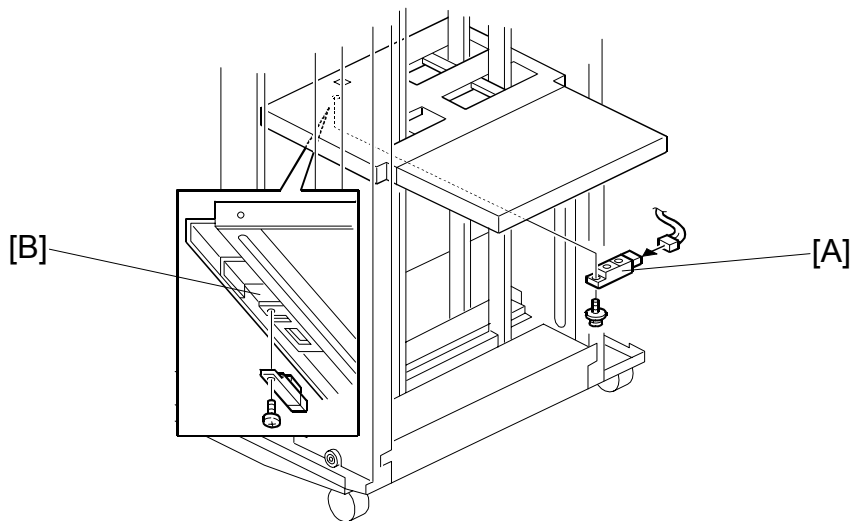

C625R12.WMF

Replacement
Adjustment



[A]: Paper end sensor ( x 1,  x 1)

- NOTE:** 1) Push the paper lifting switch to move up the paper feed table before you start work.
2) Make sure that the paper end sensor [A] is put in the bracket [B] firmly.

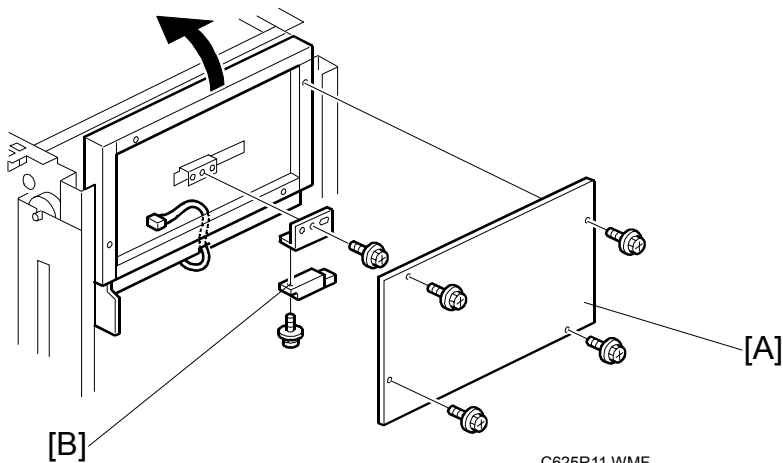
Paper length sensor



C625R11.WMF

[A]: Under paper feed table cover ( x 4)
[B]: Paper length sensor ( x 1,  x 1)

Paper table upper limit sensor
Paper table height sensor

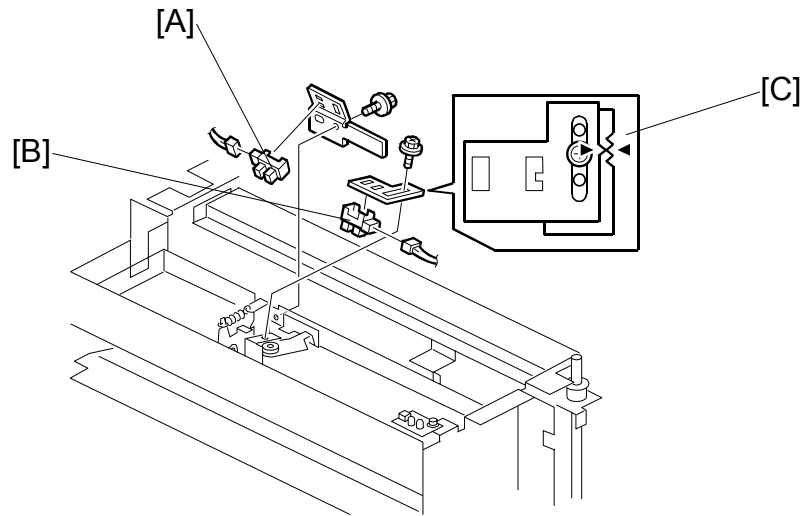

C625R02.WMF

- Top cover (☛ 3.2.1)

[A]: Paper table upper limit sensor (☛ x 1)

[B]: Paper table height sensor (☛ x 1)

CAUTION: Set the paper height sensor bracket as shown in the illustration [C] above

Paper table lower limit sensor

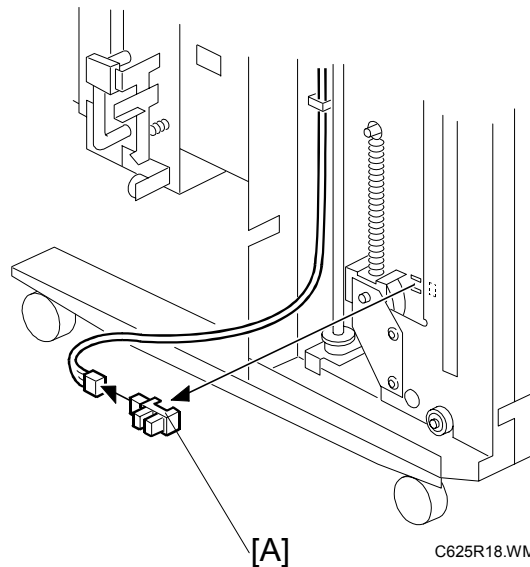

C625R18.WMF

- Front cover (☛ 3.2.1)

NOTE: Move the paper feed side fence to the center.

[A]: Paper table lower limit sensor (☛ x 1)

NOTE: Push off the sensor from the inside.

Paper table lifting switch

Paper table lowering switch

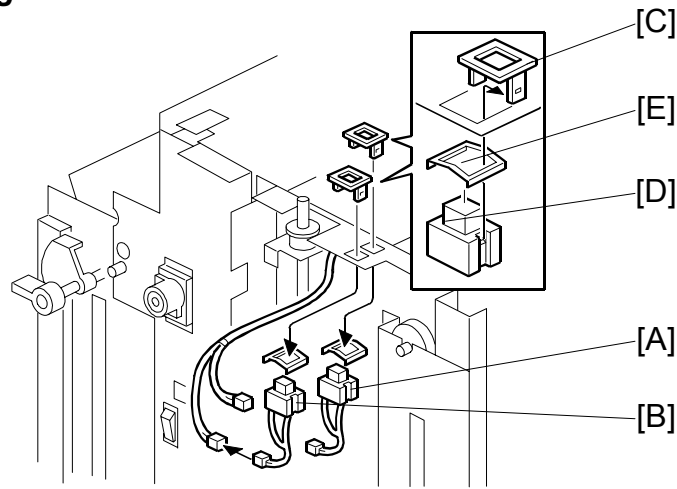

C625R17.WMF

Replacement Adjustment

- Top cover (☛ 3.2.1)

[A]: Paper table lifting switch (☛ x 1)

[B]: Paper table lowering switch (☛ x 1)

NOTE: 1) The white frame [C] goes in from the top.

2) Install the switch [D] and metal frame [E] from below.

3) Paper table lifting switch [A] (3 pins) and paper table lowering switch [B] (2 pins) is different from each other.

Feed table drive harness

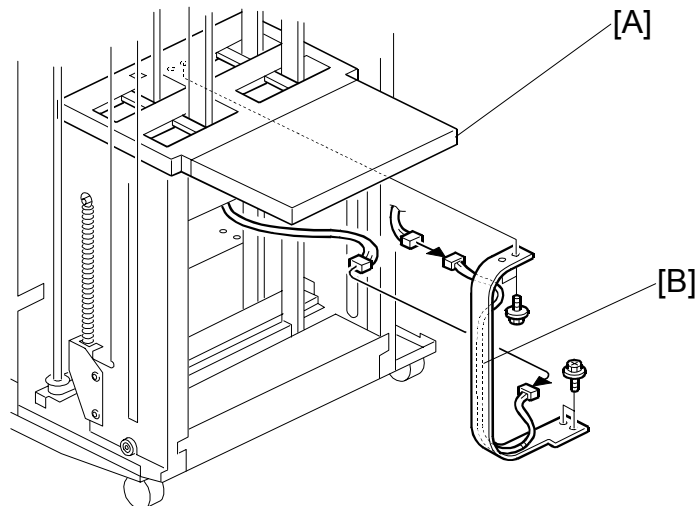

C625R13.WMF

[A]: Remove the under paper feed table cover [A] (☛ 3.2.4)

[B]: Feed table drive harness (☛ x 4, ☛ x 3)

NOTE: Push the paper lifting switch to move up the paper feed table before you start work.

3.2.4 PAPER FEED

Paper feed roller

Paper separation roller

Friction pad

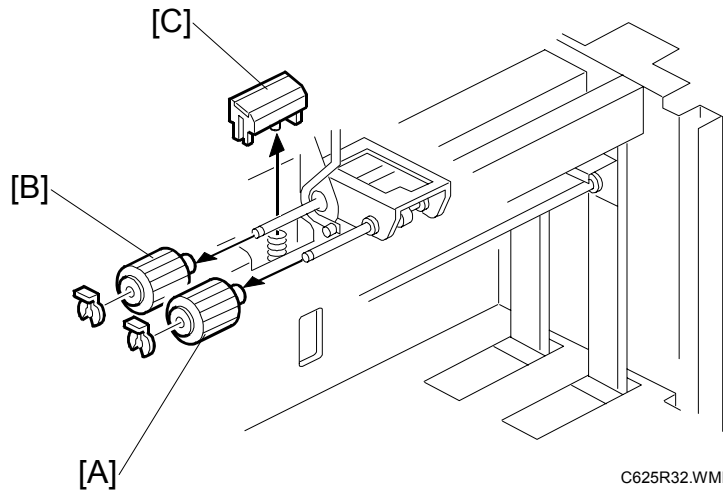

C625R32.WMF

- [A]: Paper feed roller (☺ x 1)
- [B]: Paper separation roller (☺ x 1)
- [C]: Paper friction pad

Paper feed roller unit

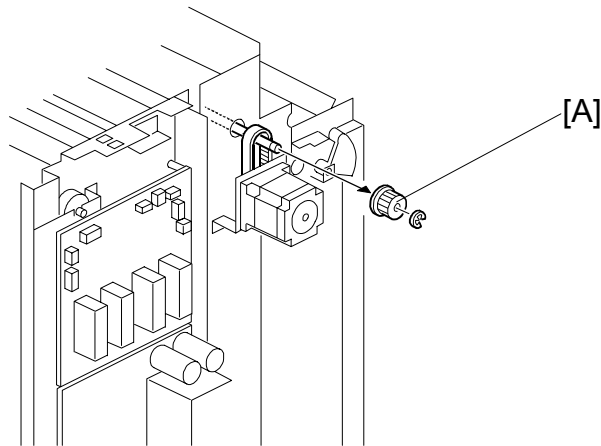

C625R26.WMF

Replacement
Adjustment

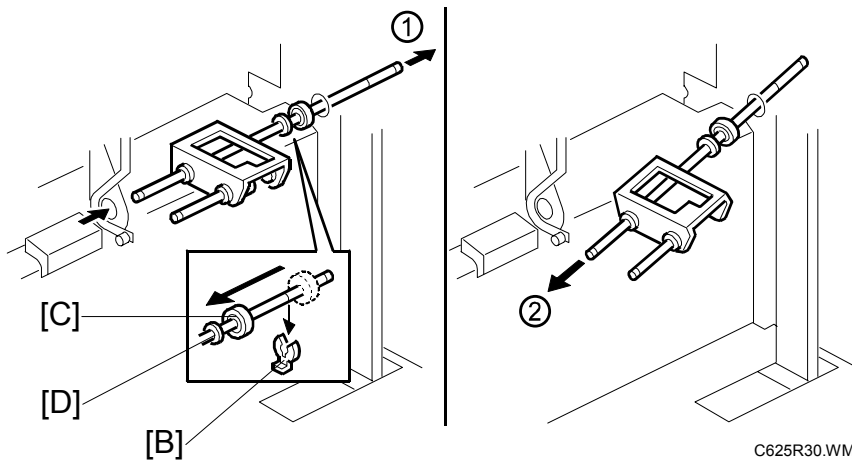

C625R30.WMF

• Rear side cover (☛ 3.2.1)

1. Pulley [A] (☉ x 1)
2. Remove a snap ring [B], then push the bearing [C] and spacer [D] inside.
3. Push out the paper separation roller shaft (1) and remove the paper feed roller unit (2).

NOTE: Be careful not to damage the mylar above the feed roller unit when you remove the paper feed roller unit.

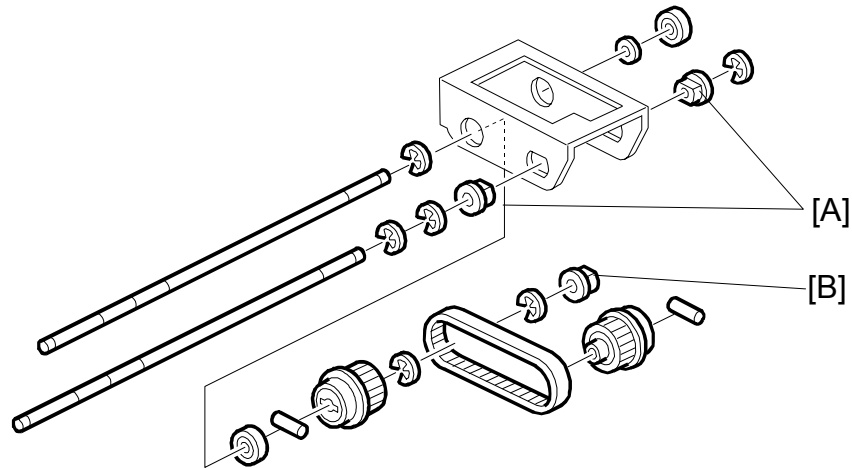
Paper feed bushing***Paper separation bushing***

C625R31.WMF

[A]: Paper feed bushing

[B]: Paper separation bushing

Lubricate with Motor Oil

Paper separation pressure adjustment

- If paper-feed jams frequently occur, move the screw [A] up or down to adjust the paper separation pressure.

To increase the pressure, move the screw up
(Multi-page feed).

To decrease the pressure, move the screw down
(No paper fed).

NOTE: Before you adjust the paper separation pressure, adjust the position of the pressure adjustment lever.

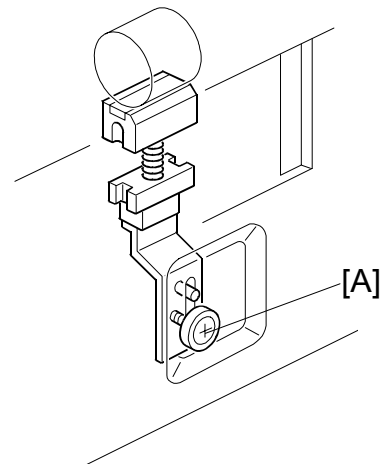

C625D906.WMF

3.2.5 INTERMEDIATE FEED SECTION

Upper feed roller spring

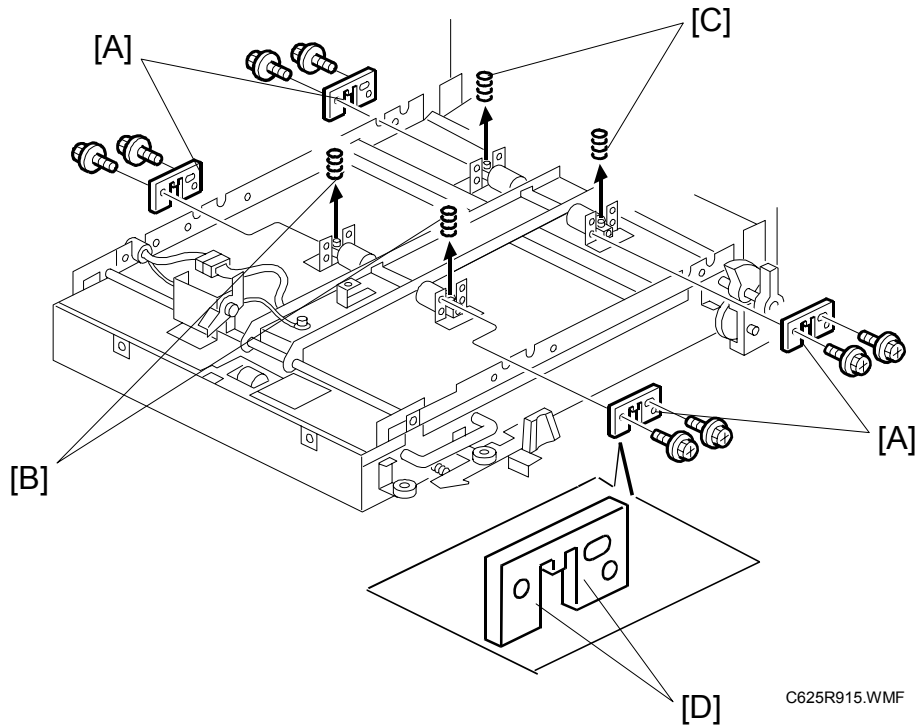

C625R915.WMF

Replacement
Adjustment

- Intermediate upper cover (☛ 3.2.1)
- [A]: Upper feed roller bracket (☛ x 2)
- [B]: Upper feed roller black spring
- [C]: Upper feed roller silver spring

Apply grease (Shell Albania 2) to the spring brackets [D] for the feed roller springs [B, C].

CAUTION: Apply grease only to the spring bracket.

Intermediate upper feed roller

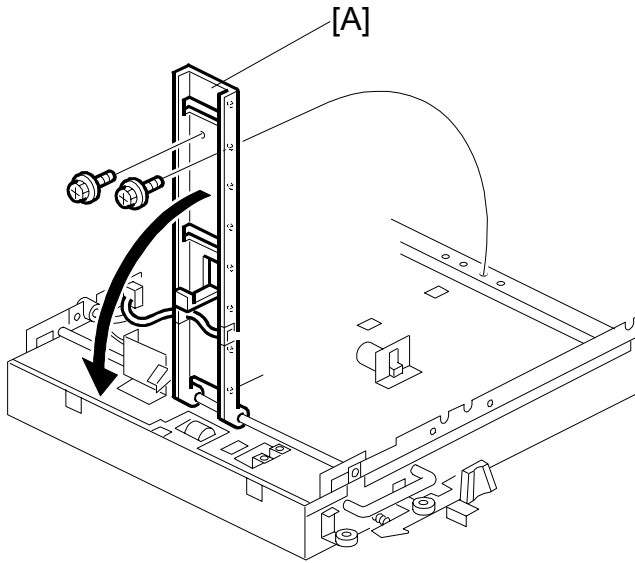

C625R905.WMF

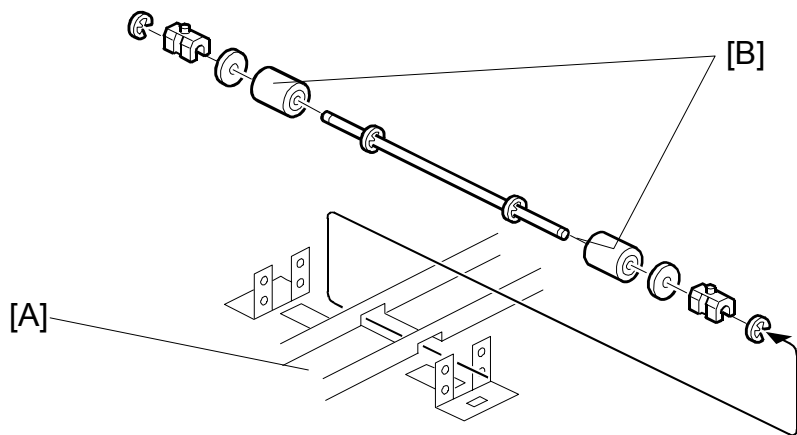

C625R05.WMF

- Intermediate upper cover (☛ 3.2.1)
- [A]: Intermediate paper sensor stay (⚙ x 2, ⚙ x 1)
- [B]: Intermediate upper feed roller (⚙ x 4, ⚙ x 2)

Intermediate under feed roller

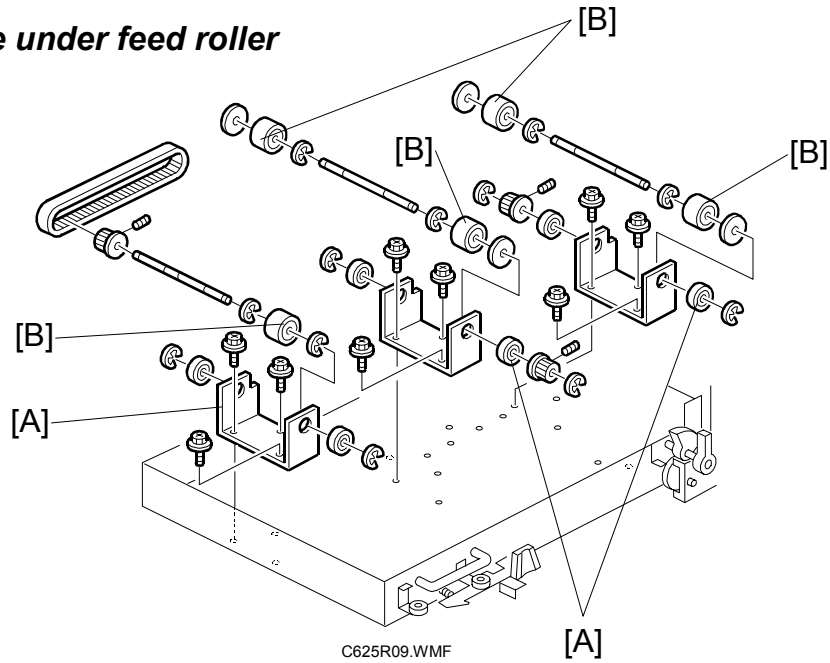

Replacement Adjustment

- Intermediate under cover (☛ 3.2.1)
- [A]: Intermediate under feed roller bracket (🔩 x 3)
- [B]: Intermediate under feed roller (🌀 x 3)

Intermediate paper feed sensors

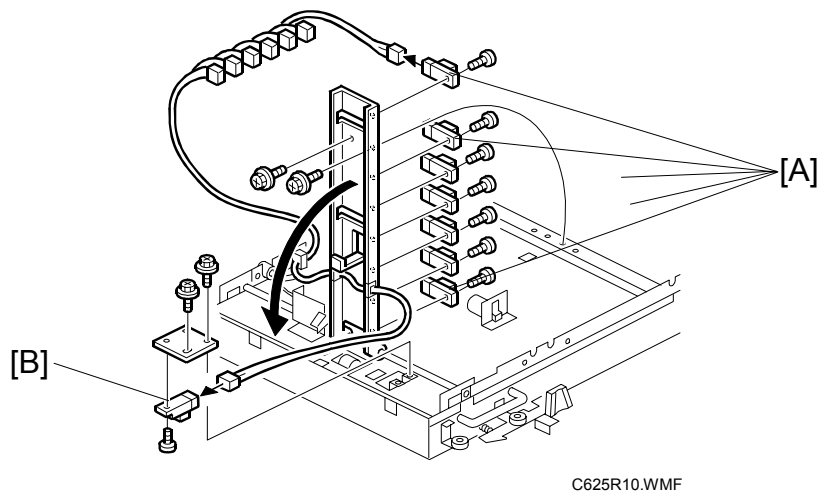

1st to 7th sensors

- Intermediate under cover (☛ 3.2.1)
- [A]: 1st to 7th sensors (🔩 x 1, 📡 x 1)

8th sensor

- Intermediate under cover (☛ 3.2.1)
- [B]: 8th sensor (🔩 x 1, 📡 x 1)

Paper end solenoid
Paper length solenoid

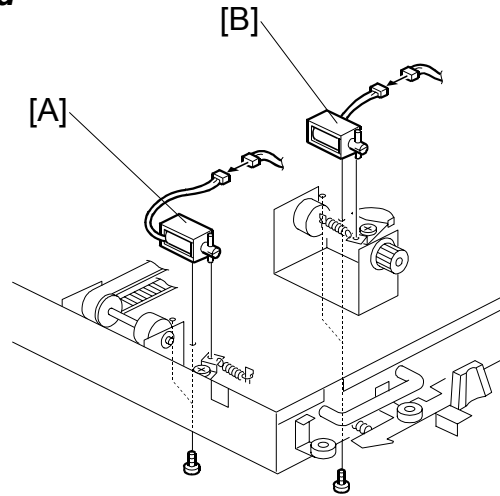

C625R06.WMF

- Intermediate under cover (☛ 3.2.1)
- [A]: Paper end solenoid (⚙️ x 2, 📌 x 1)
 [B]: Paper length solenoid (⚙️ x 2, 📌 x 1)

Brake guide

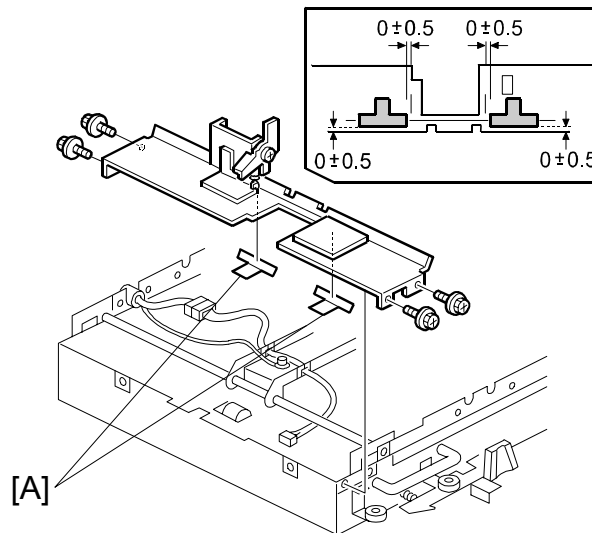

C625R29.WMF

- [A]: Brake guide (⚙️ x 4, 📌 x 1)
NOTE: On the bracket, use alcohol to clean the surface where the mylar will be attached.

3.2.6 DRIVE

Paper feed motor

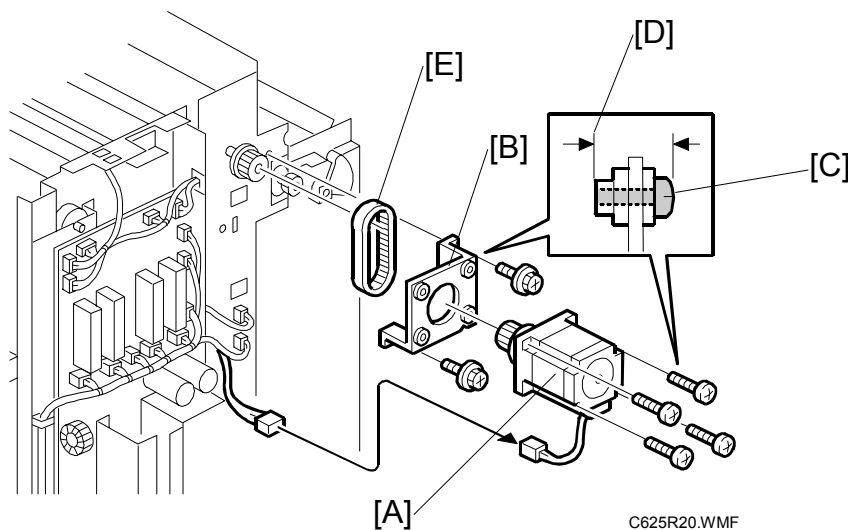

Replacement
Adjustment

- Rear side cover (☛ 3.2.1)

[A]: Paper feed motor (🔩 x 4, 📏 x 1)

NOTE: When you attach the motor to the bracket [B], do not screw in the screws [C] past the end of the rubber sections [D].

Paper feed motor belt

[E]: Paper feed motor belt (🔩 x 2)

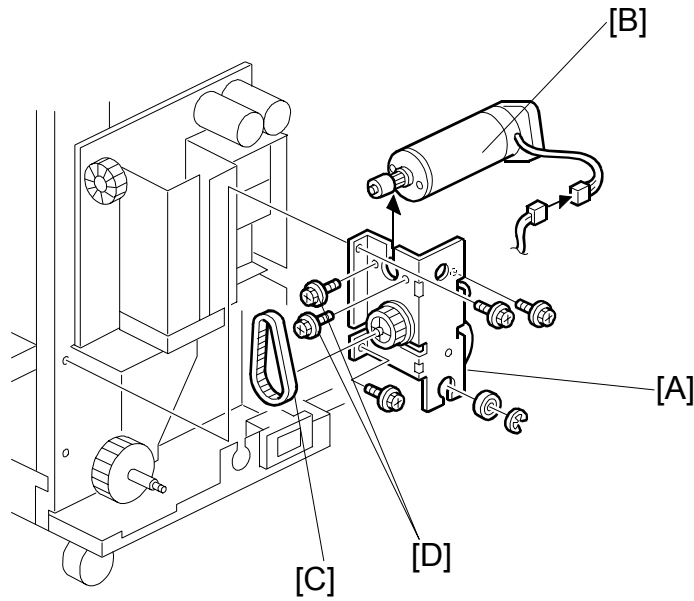
Paper table motor

C625R19.WMF

- Rear cover (☛ 3.2.1)

CAUTION: Lower the paper feed table before you remove the paper table drive unit, or the table will fall.

[A]: Paper table drive unit (☛ x 3)

[B]: Paper table motor (☛ x 2)

Paper table motor belt

[C]: Paper table motor belt (loosen ☛ x 2 [D])

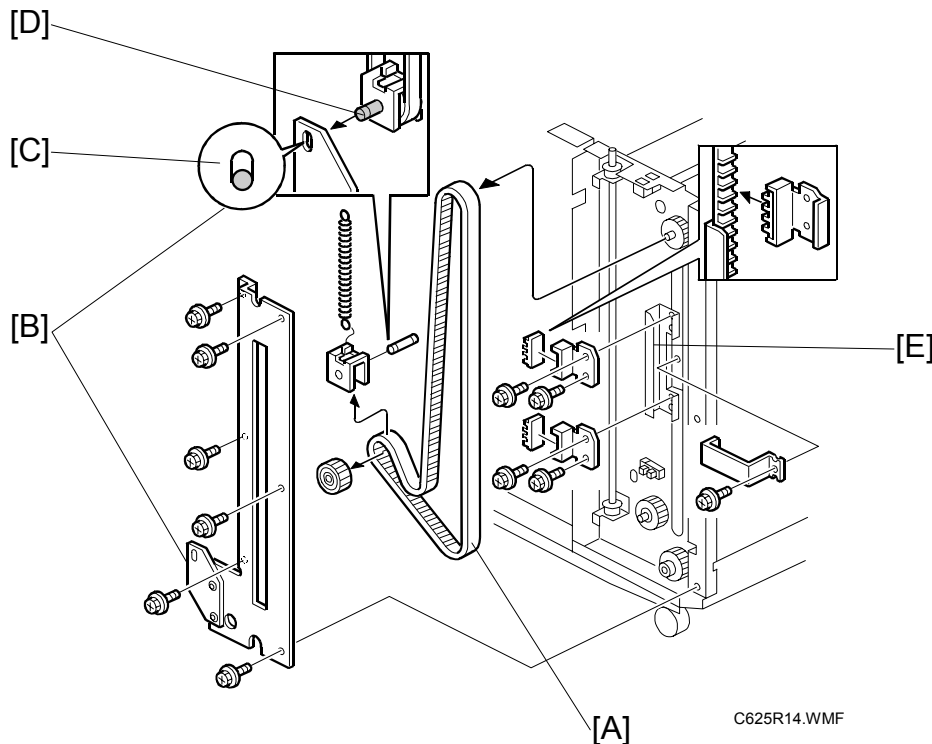
Paper table drive belt

Replacement
Adjustment

Do this procedure at the operation side and at the non-operation side.

Front cover (☛ 3.2.1)

Remove these parts at the non-operation side of the machine:

- PSU
- MPU
- Paper table motor unit

CAUTION: Lower the paper feed table before you remove the paper table drive belt, or the table will fall.

[A]: Paper table drive belt (☛ x 6)

CAUTION: 1) The paper feed table must be level when you install the paper table drive belts.

2) Adjust the tension pulley bracket [B] (☛ x 2) until the bottom of hole [C] touches the tension pulley shaft [D].

3) Install the paper table drive belt bracket [E] the correct way around.

Intermediate paper feed motors

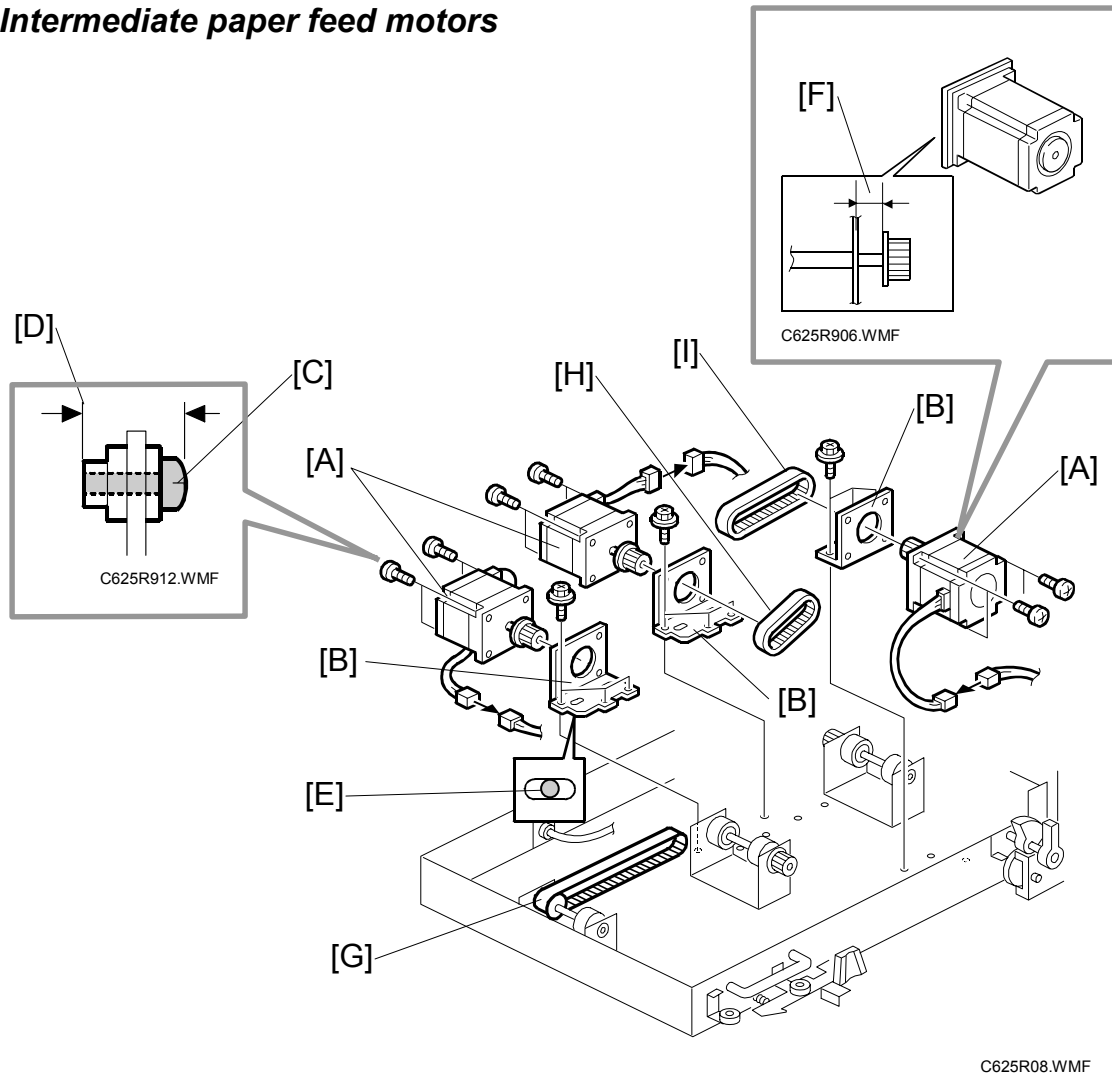

- Intermediate under cover (☛ 3.2.1)

[A]: Intermediate paper feed motor (☛ x 7, ☛ x 1)

NOTE: 1) When you install the paper feed motor bracket [B], make sure that the projection is at the center of the hole [E] in the bracket.

2) The gap [F] between the pulley and shaft must be 6 mm.

3) When you attach the motor to the bracket [B], do not screw in the screws [C] past the end of the rubber sections [D].

Intermediate paper feed motor belt

[G] [H] [I]: Intermediate paper feed motor belt

Loosen the intermediate paper feed motor bracket [B] (☛ x 3).

3.2.7 SIDE FENCE

Side fence adjustment belt (top and bottom)

Top

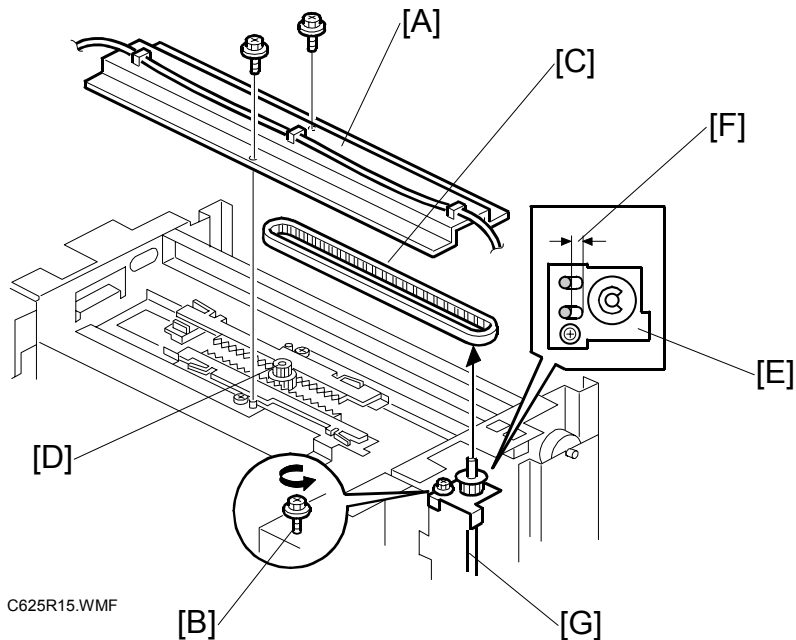

Replacement
Adjustment

- Top cover (☛ 3.2.1)

[A]: Paper dust cover (☛ x 2)

Loosen the screw [B].

Pull out the side fence adjustment belt [C]. Pinion [D] can also be removed.



- NOTE:** 1) Adjust the belt tension with the bracket [E]. The gap [F] must be more than 1.5 mm.
2) When you remove the side fence adjustment belt, move the side fences as far apart as possible.

Bottom

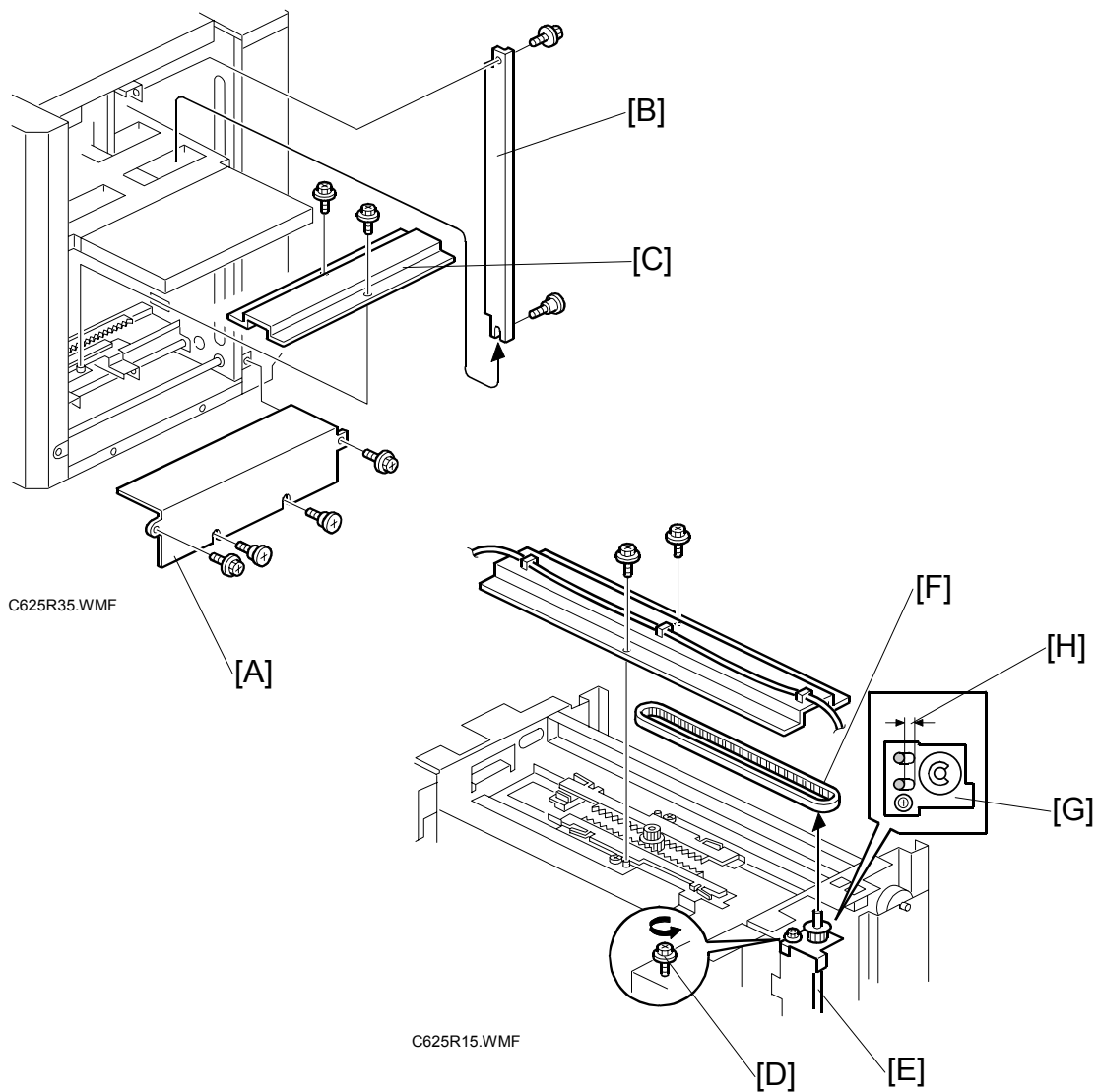

Front cover (☛ 3.2.1)

[A]: Bottom cover (☛ x 4)

[B]: Side fence (☛ x 2)

[C]: Paper dust cover (☛ x 2)

Examine the illustration above. Then do the procedure.

Loosen the screw [D].

[E]: Side fence adjustment shaft (☛ x 1)

Pull out the side fence adjustment belt [F].

NOTE: 1) Adjust the belt tension with the bracket [G]. The gap [H] must be more than 1.5 mm.

2) When you remove the side fence adjustment belt, move the side fences as far apart as possible.

3) The belt tension at the top and bottom must be the same.

Paper width detection board

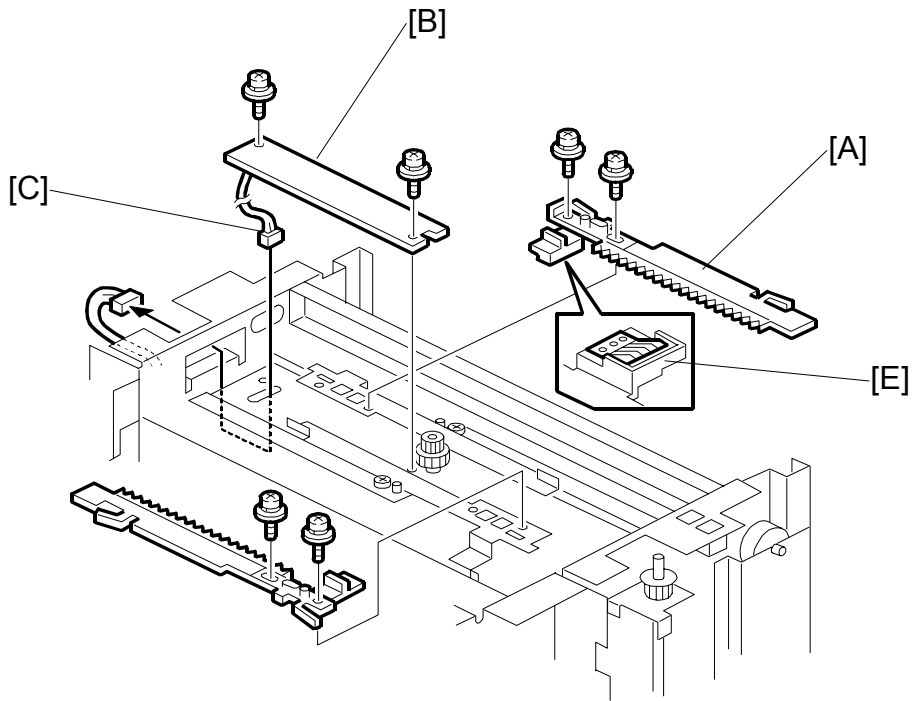

C625R16.WMF

Replacement Adjustment

- Top cover (☛ 3.2.1)
- Side fence adjustment belt (☛ 3.2.7)
- [A]: Rack (☛ x 2)
- [B]: Paper width detection board (☛ x 2)

NOTE: Move the side fences together as close as possible when you install the rack.

CAUTION: Be careful when you remove the rack [A], because there are metal legs [E] below the rack. These make sure that you do not install the harness [C] incorrectly.

3.3 LCOT

3.3.1 COVERS

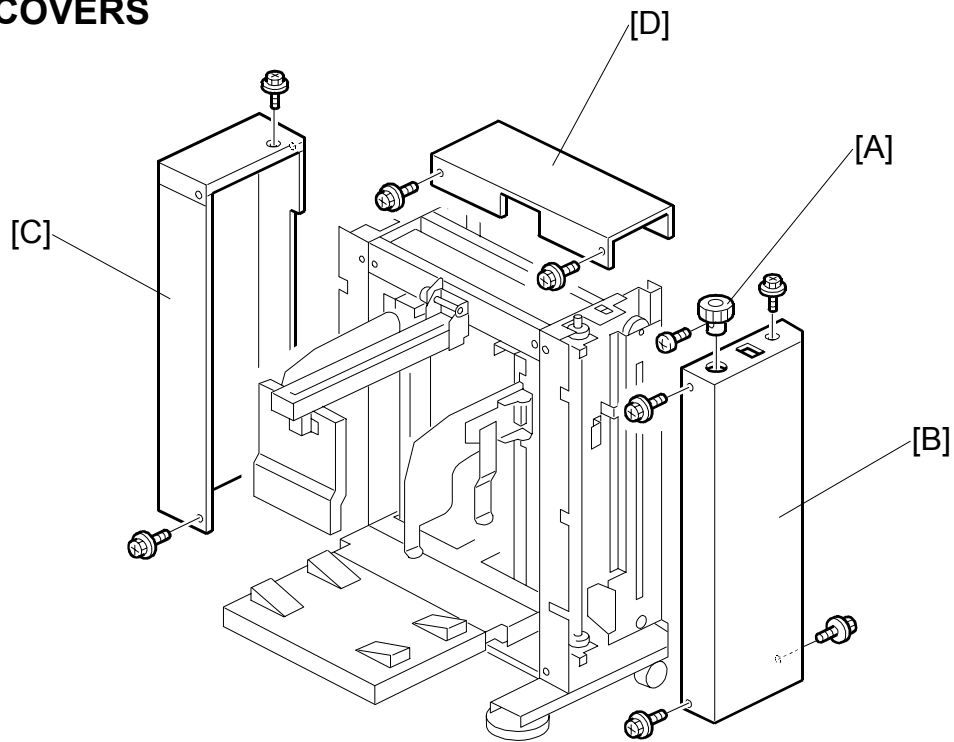

C625R24.WMF

Front cover

[A]: Knob (🔩 x 1)

[B]: Front cover (🔩 x 4)

Rear cover

[C]: Rear cover (🔩 x 5)

Top cover

[D]: Top cover (🔩 x 2)

3.3.2 BOARD

MPU

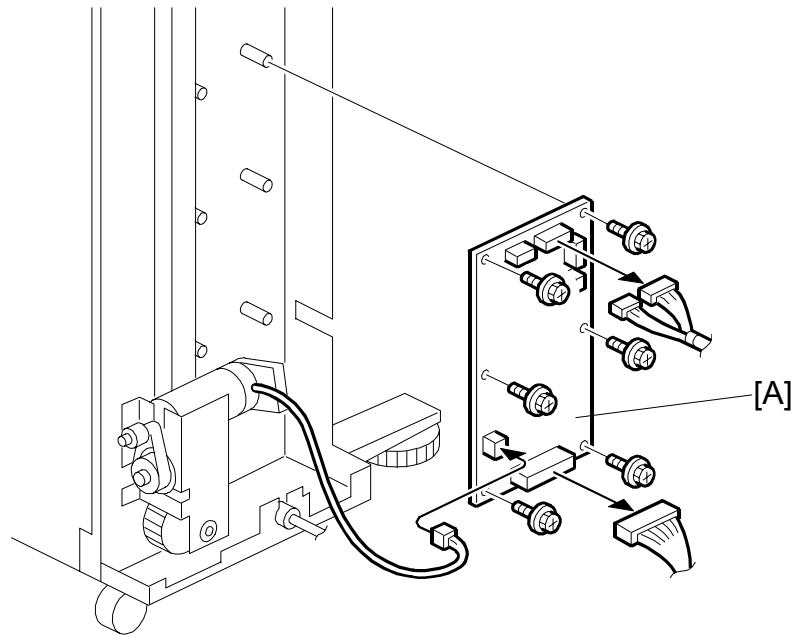

Replacement
Adjustment

- Rear cover (☛ 3.3)
- [A]: MPU (🔩 x 6, 📏 x 4)

NOTE: 1) Check the dip switch settings on the old MPU and make the dip switch settings [B] the same on the new MPU.
2) Make sure that the EPROM on the MPU contains the correct firmware.

3.3.3 FIRMWARE UPDATE

To upgrade the firmware in the EPROM on the MPU – LCOT, replace the EPROM.

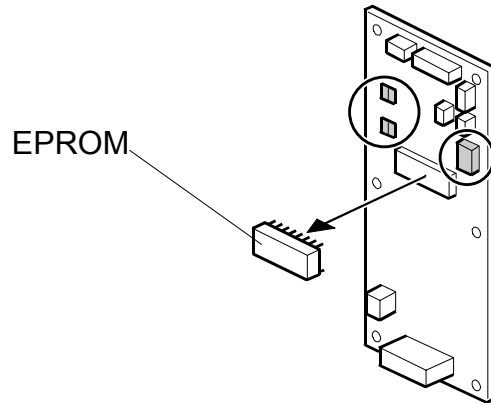

C625R911.WMF

NOTE: Before you upgrade the firmware, check the current suffix version on the EPROM label.

1. Turn off the main switch and disconnect the power plug.
2. Remove the rear cover.
3. Replace the EPROM on the MPU - LCOT.
4. Check if the machine works properly after replacing the EPROM.

3.3.4 DELIVERY TABLE

Paper table upper and lower limit sensors

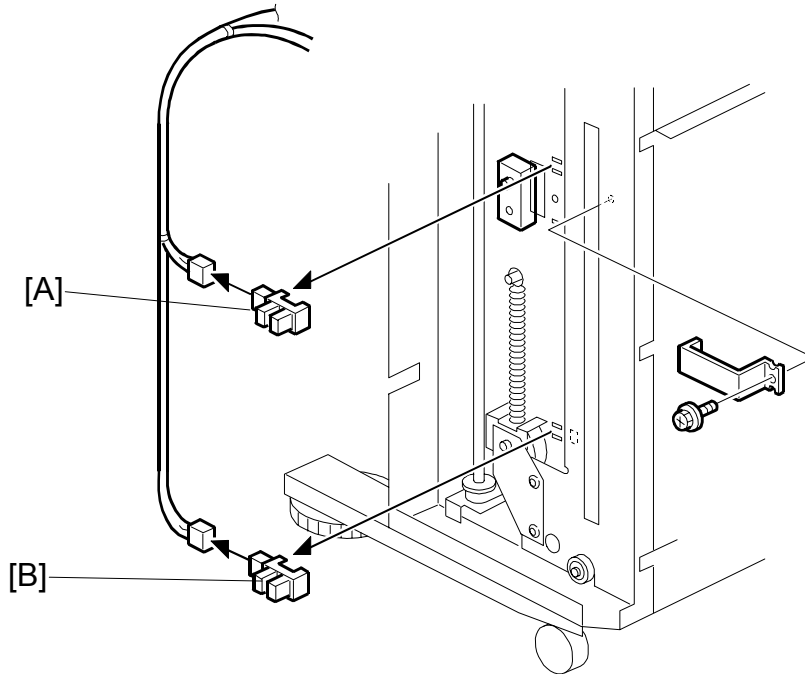

C625R913.WMF

Replacement
Adjustment

- Front cover (☛ 3.3)
- [A]: Paper table upper limit sensor (☛ x 1)
- [B]: Paper table lower limit sensor (☛ x 1)

NOTE: The paper table lower limit sensor for the LCOT is in the same position as on the LCIT.

Paper table lifting and lowering switch

(☛3.2.4)

3.3.5 END FENCE

End plate arm

(☛ 1.2.2)

End plate release sensor

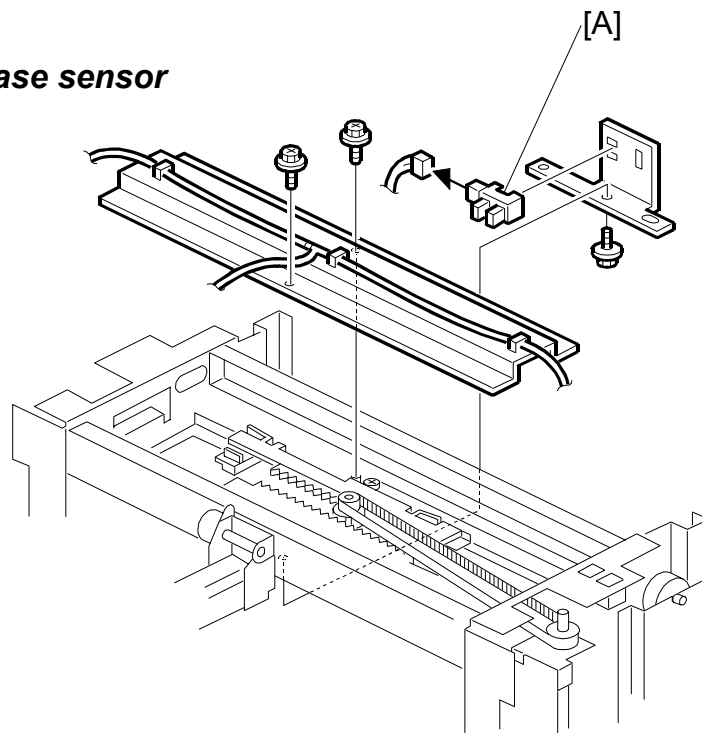

C625R27.WMF

- Top cover (☛ 3.3)

[A]: End plate release sensor (☛ x 1, ☛ x 1)

3.3.6 DRIVE

Paper table motor

(☛ 3.2.6)

Paper table motor belt

(☛ 3.2.6)

Paper table drive belt

(☛ 3.2.6)

3.3.7 SIDE FENCE

Side fence adjustment belt (top and bottom)

(☛ 3.2.7)

Paper delivery side plate

(☛ 1.2.2)

Side fence guide

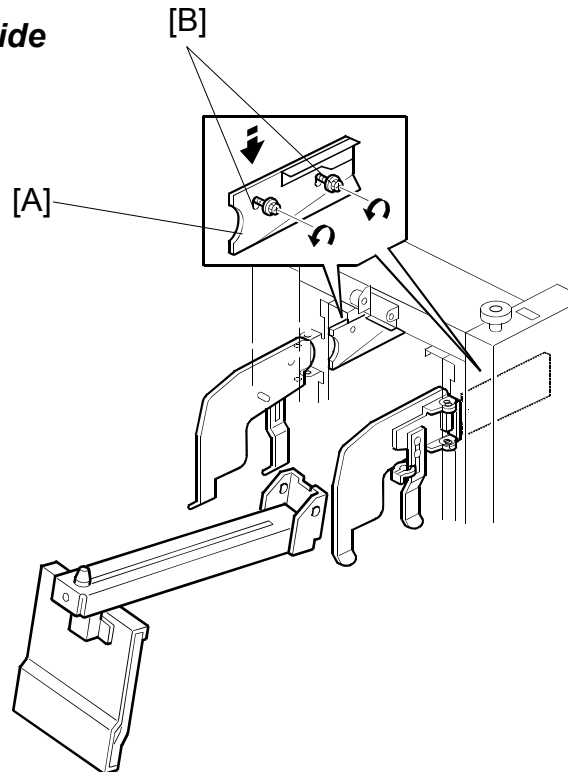

C625R904.WMF

[A]: Side fence guide (☛ x 2)

[B]: Side fence guide adjustment screws (☛ x 2); adjust after replacing [A]

Adjustment

Loosen two screws [A] at both sides of the side fence guide board. Move the side fence guide board [B] down as far as possible, and tighten the screws again.

- Model C593 only -

NOTE: Move the side fence guide board up as far as possible.

Paper amount sensor

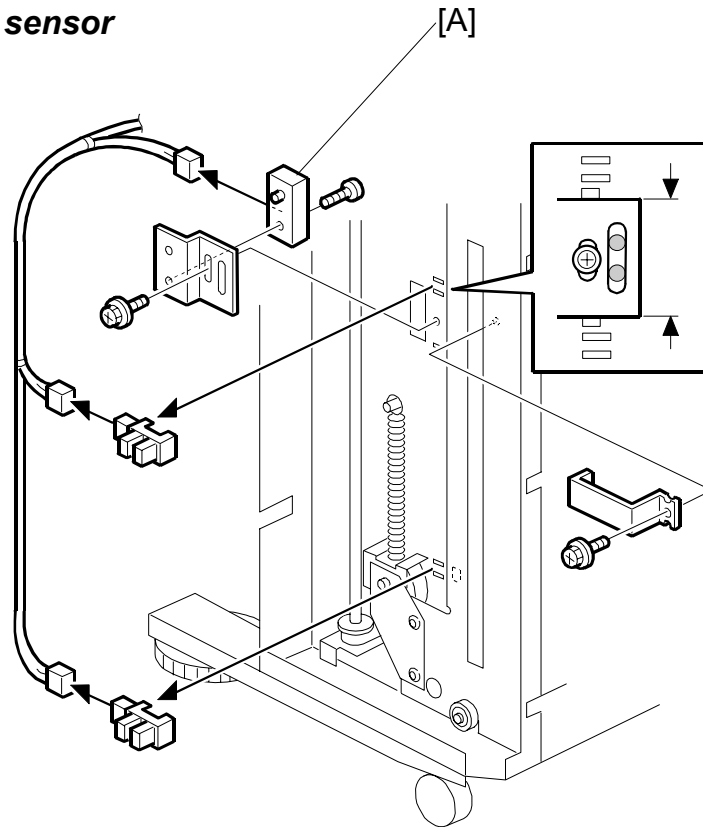

C625R28.WMF

- Front and rear cover (☛ 3.3)
- [A]: Paper amount sensor (☛ x 4, ☛ x 4)
- Amount of descent adjustment (☛ 4.3.4)

4. TROUBLESHOOTING

4.1 ERROR INDICATORS

4.1.1 LED

Red LED	Green LED	Cause
Lit	-	Service Call
Blinking	-	Paper jam
-	Lit	Ready to start printing ^{note1}
-	Blinking	Standby mode ^{note2}
Blinking	Blinking	Intermediate upper cover lever is open

NOTE: 1) Paper is in the intermediate feed section. Print will start when you push the print key on the duplicator.

2) The LCIT is ready to feed paper. Load the paper. Then push the paper-lifting switch.

4.1.2 SERVICE CALL

Sign: The red LED is lit

Problem: The paper feed table is stuck

Condition: 1) When the paper feed table moves up more than 15 seconds, and the paper table height sensor does not detect the table.

2) When the paper feed table moves down more than 15 seconds, and the paper lower limit sensor does not detect the table.

Cause: Defective paper table height sensor or paper table lower limit sensor.

Defective paper table motor.

4.2 ELECTRICAL COMPONENT DEFECTS

4.2.1 LCIT

Component	Condition	Symptom
Intermediate upper cover release sensor	Shorted	Standby state blinks green during unlock the Intermediate upper cover.
	Open	Cannot be in standby mode (blink green).
Paper table lower limit sensor	Shorted	Lifting SW ON - Table moves up to height sensor Lowering SW ON - Table does not move down Table does not move down when you remove paper.
	Open	Lifting SW ON - Table moves up to height sensor Lowering SW ON - Table moves down lower than limit position. The SC (light red) will go ON after the motor moves more than 15 seconds. This will also occur when you remove the paper.
Paper table height sensor	Shorted	Lifting SW ON - Table does not move up If table is not at feed position, it will be paper non-feed (blink red). When table is at feed position, it will feed all paper on table and after that it will be paper non-feed (blink red).
	Open	Lifting SW ON - Table moves up. SC (light red) will go ON after the motor moves more than 15 seconds.
Paper table upper limit sensor	Shorted	If table is not at feed position, it will be paper non-feed (blink red). After you clear the jam, SC (light red) will go ON if lifting SW is turned on again.
	Open	Lifting SW ON - SC (light red) will go ON after the motor moves more than 15 seconds. (If paper table height sensor detects the paper, the motor stops.
Paper table lowering switch	Continue shorted	Lifting SW ON - Table does not move up Lowering SW ON - Table does not move down No paper - Table does not move down
	Continue open	Lifting SW ON - Table does not move up Lowering SW ON - Table does not move down No paper - Table moves down
Paper table lifting switch	Continue shorted	Lifting SW ON - Table does not move up Lowering SW ON - Table does not move down No paper - Table does not move down
	Continue open	Lifting SW ON - Table does not move up Lowering SW ON - Table does not move down No paper - Table moves down
Paper width detection sensor	Shorted	Paper non-feed may occur
	Open	Paper non-feed may occur
Paper end sensor	Shorted	With paper - Normal movement No paper - paper feed jam Standby with no paper - Table does not move down.
	Open	Power SW ON - Table moves down. Lifting SW ON - Table does not move up

Component	Condition	Symptom
Paper length sensor	Shorted	Paper non-feed may occur
	Open	Paper non-feed may occur
Intermediate 1st paper feed sensor	Shorted	Power SW ON - paper non-feed (blink red)
	Open	Lifting SW ON - paper non-feed (blink red)
Intermediate 2nd to 8th paper feed sensor	Shorted	Power SW ON - paper non-feed (blink red)
	Open	Lifting SW ON - after paper feed to duplicator. Then paper non-feed (blink red)

4.2.2 LCOT

Component	Condition	Symptom
Paper amount sensor	Shorted	Power SW ON - Table moves down a little after 3 sec. Then move down a little every 20 sec to lower limit sensor. Lifting SW ON - Table does not move up Lowering SW ON - Table moves down
	Open	Table does not move down with stack of paper Lifting SW ON - Table moves up Lowering SW ON - Table moves down
Paper table lifting switch	Continue shorted	Table doesn't move down with stack of paper Lifting SW ON - Table doesn't move up Lowering SW ON - Table doesn't not move down
	Continue open	Table moves down with stack of paper Lifting SW ON - Table doesn't move up Lowering SW ON - Table moves down
Paper table lowering switch	Continue shorted	Table doesn't move down with stack of paper Lifting SW ON - Table doesn't move up Lowering SW ON - Table doesn't move down
	Continue open	Table moves down with stack of paper Lifting SW ON - Table moves up Lowering SW ON - Table doesn't move down
Paper table upper limit sensor	Shorted	Table moves down with stack of paper Lifting SW ON - Table doesn't move up Lowering SW ON - Table moves down
	Open	Table doesn't move down with stack of paper Lifting SW ON - Table moves up for 15 sec and stop. After that table doesn't move down though you turns on lowering SW.
Paper table lower limit sensor	Shorted	Table don't move down with stack of paper Lifting SW ON - Table moves up Lowering SW ON - Table doesn't move down
	Open	Table doesn't move down with stack of paper Lifting SW ON - Table moves up Lowering SW ON - Table moves down for 15 sec and stop. After that table doesn't move up though you turns on lowering SW.

Trouble-shooting

Component	Condition	Symptom
End plate release sensor	Shorted	Table moves down with stack of paper Lifting SW ON – When you lift the table, it doesn't stop when you raise end plate arm Lowering SW ON - Table moves down
	Open	Table doesn't move down with stack of paper Lifting SW ON - Table doesn't move up Lowering SW ON - Table doesn't move down

4.3 CHECK POINTS FOR PROBLEMS

4.3.1 WRONG PAPER SIZE DETECTION

Phenomenon:

The duplicator does not correctly detect the paper size.

Solution 1

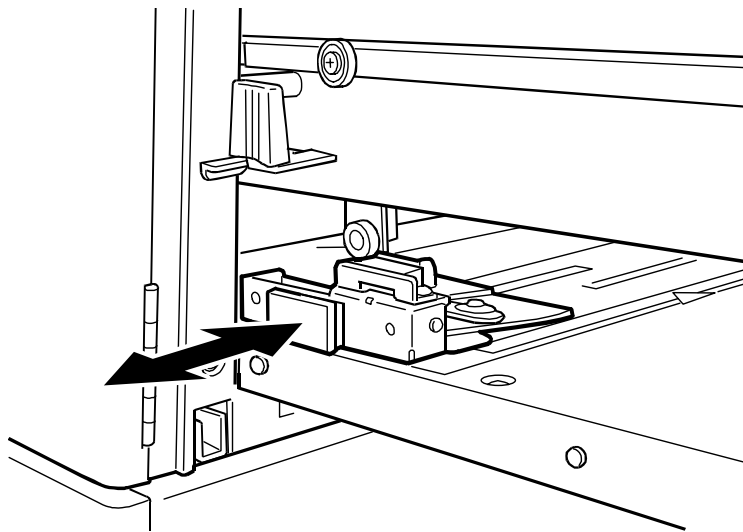

C625T902.WMF

Trouble-
shooting

Adjust the paper feed side plate for the duplicator to the size of paper set at the LCIT. Then, make sure that the paper size is shown on the operation panel.

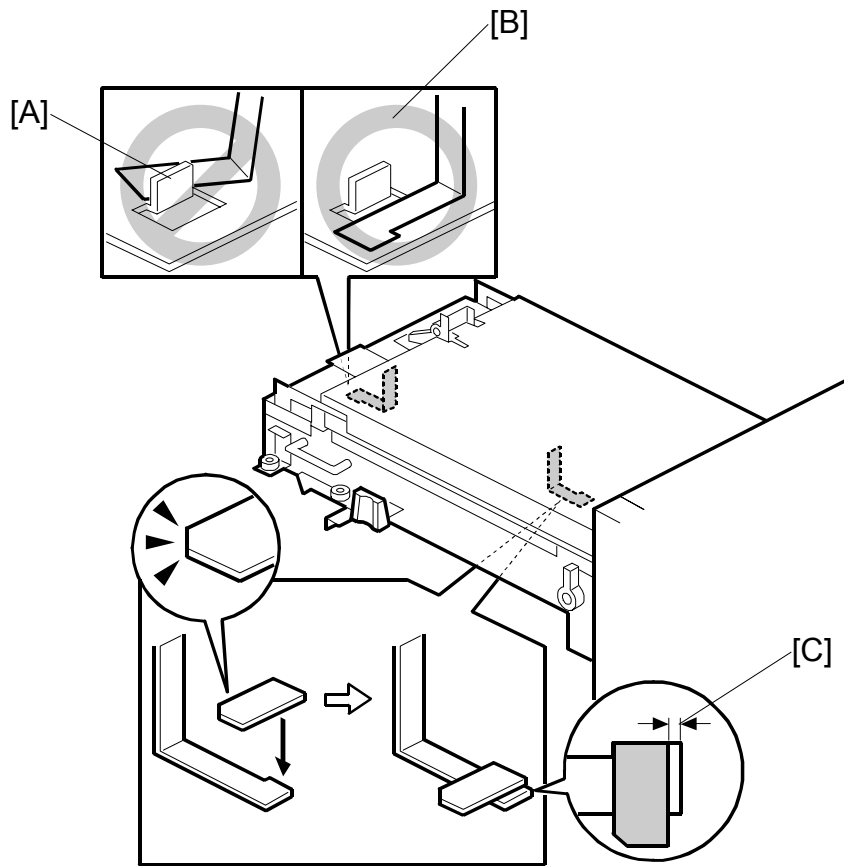
Solution2

C625T905.WMF

1. Set paper larger than B4 (8 1/2" x 14"), which covers the paper length sensor on the paper feed table for the LCIT. Then, feed the paper into the intermediate feed section. Push the paper table lifting switch to do this.

Make sure the paper size is shown on the control panel.

If the paper size is not shown correctly, examine these:

- 1) The paper end sensor on the duplicator is covered by the paper end mylar below the intermediate feed section.

NO: The paper end mylar may be positioned behind the pawl [A].

Move the mylar back to the correct position [B].

- 2) The paper length sensor on the duplicator is covered by the paper length mylar below the intermediate feed section.

NO: - Model **C229/C233/C239** only -

The long guide of the beveled edge must be as shown in the drawing, and the gap [C] must be 2 to 3 mm.

4.3.2 SHIFTED PRINTING POSITION

Phenomenon:

The image moves vertically after you install the LCIT.

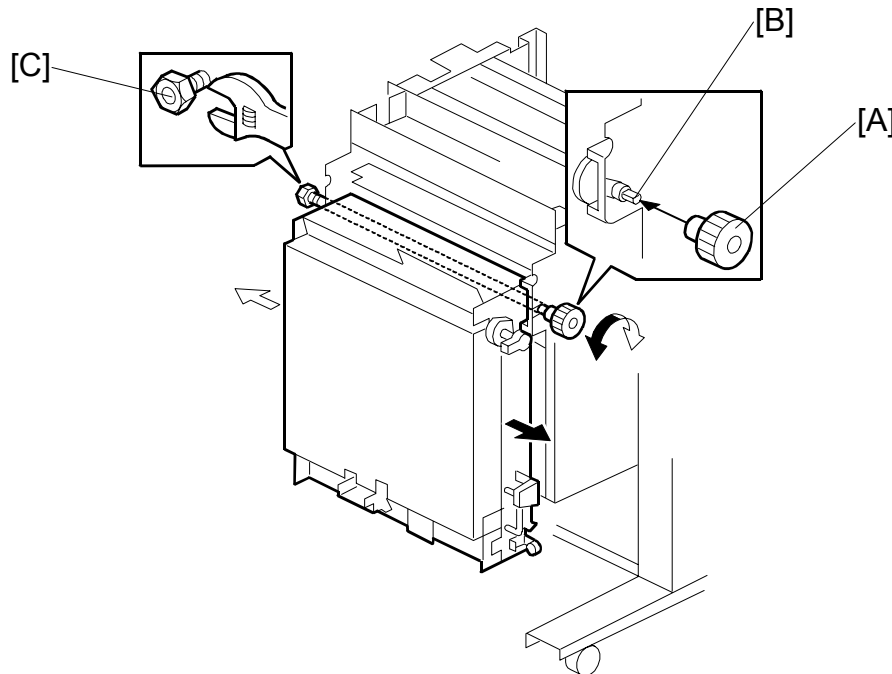

C625T906.WMF

Trouble-
shooting

Solution

1. Open the side front cover. (☛ 3.2.1)
2. Remove the side fence adjustment knob [A] (🔩 x 1)
3. Put the knob [A] into the shaft [B]
4. Loosen the nut [C].
5. Turn the knob [A].
 - Turn right ⇒ Moves the image to the non-operation side
 - Turn left ⇒ Moves the image to the operation side

NOTE: 1) Make sure there is no image shift by the duplicator without LCIT before you adjust the LCIT.

2) Do not do this when the LCIT is installed in the duplicator.

3) The intermediate feed section lifts up a little when the knob is turned.

4) It moves 1.5mm for one turn of the knob.

5) The maximum adjustment is 2 mm up or down.

4.3.3 PAPER NON-FEED

Phenomenon

Paper does not feed correctly.

Solution 1

Clean the paper feed and separation roller for a duplicator.

Solution 2

Adjust the paper separation lever. (☛ 3.3.2)

Solution 3

Adjust the paper separation pressure. (☛ 3.2.5)

Solution 4

Use the SP mode for the duplicator

- 1) Change the feed pressure values (for normal and thick paper) to 6 with following SP mode.

Model Number	Paper Feed Pressure (SP mode number)	Setting
C239	SP 6 - 9 - 1 to SP 6 - 9 - 6	6
C235	SP 6 - 9 - 1 to SP 6 - 9 - 6	
C244	SP 6 - 9 - 1 to SP 6 - 9 - 6	
C229	SP6 - 91 - 1 to 3 and SP6 - 92 - 1 to 3	
C233	SP6 - 91 - 1 to 3 and SP6 - 92 - 1 to 3	
C593	None	None

2) – Model C593 only –

Change the feed pressure value to 6 with a user setting (Paper Supply Adjustment). Note that if the power is set off, this setting returns to the default value.

PAPER DELIVERY ALIGNMENT

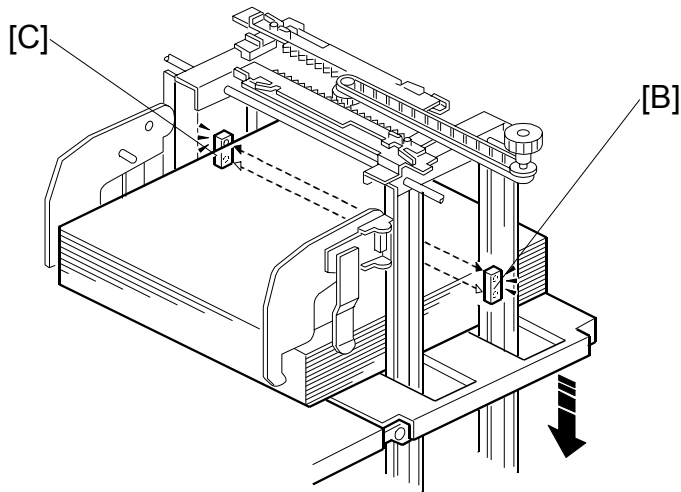

C625T907.WMF

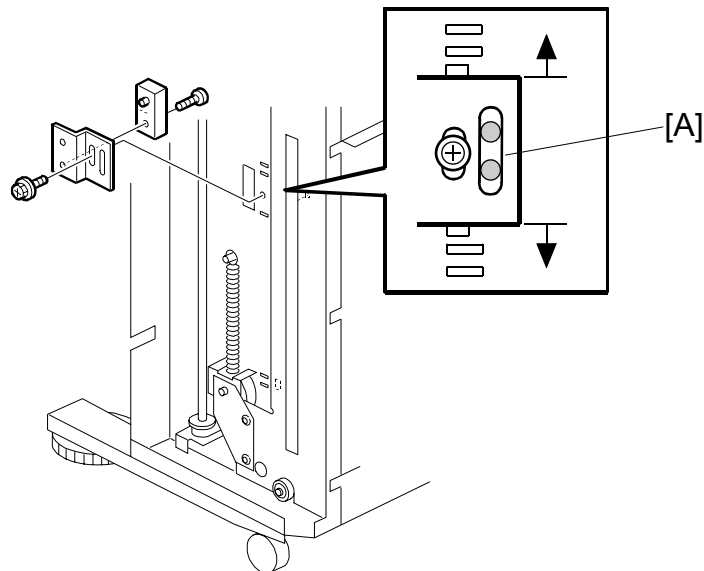

C625T901.WMF

Trouble-
shooting

Phenomenon 1

Paper alignment on the paper delivery table is defective.

Solution 1

Paper alignment on the paper delivery table is defective.

Move down the paper amount sensor bracket [A].

NOTE: The distance between the paper exit point and the loading surface becomes shorter.

Phenomenon 2

Paper falls from the paper delivery table.

Solution 1

Move up the paper amount sensor bracket [A].

NOTE: The paper amount sensor can detect the maximum paper amount early if the paper is curled, and the paper delivery table will move down too far. Then the paper will go between the paper delivery table and the bottom of the end plate.

CAUTION: You must adjust the paper amount sensor by the same amount at the operation [B] and the non-operation [C] sides.

NOTE: 1) You can adjust the bracket of the paper amount sensor 4 mm at the top and bottom sides.
2) You can adjust the amount of downward movement of the paper delivery table with SP mode. (☛ 5.1.2)

5. SERVICE TABLES

NOTE: The Service Program Mode is for use by service representatives only. If a non-service representative uses this mode, data might be deleted or settings might be changed. Product quality cannot be guaranteed in this condition.

5.1 SERVICE PROGRAM MODE

Use the service program (SP) mode to monitor electrical data, and change modes.

5.1.1 TO ENTER AND EXIT THE SP MODE - LCIT

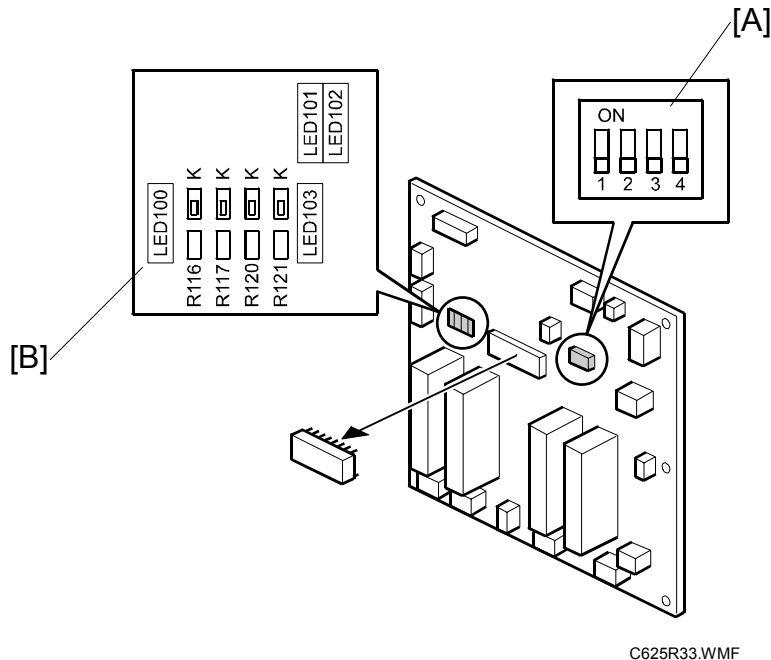

Service
Tables

1. Use dipswitch 100 [A] to operate the LCIT service programs.
2. Make sure the LCS works correctly before you go into the SP mode.
3. Write down the dipswitch 100 [A] positions on the MPU before you go into the service program mode.
4. Set dipswitch 100 [A] back to the initial positions after you complete the service mode.
5. To go out of service program mode, set the power off.

Input check

1. Set the power on while you push the paper table-lifting switch and paper table-lowering switch.
2. LED100 to 103 [B] flash for 5 seconds.
3. Set the dipswitches [A] as follows. Then examine the inputs on the LEDs [B].

Dip switch setting 1

SW100-1	SW100-2	SW100-3	SW100-4
OFF	OFF	OFF	OFF

LED100	LED101	LED102	LED103
Intermediate upper cover release sensor	Paper table lower limit sensor	Paper table height sensor	Paper table upper limit sensor

Dip switch setting 2

SW100-1	SW100-2	SW100-3	SW100-4
ON	OFF	OFF	OFF

LED100	LED101	LED102	LED103
/	Paper table lowering switch	Paper table lifting switch	/

Dip switch setting 3

SW100-1	SW100-2	SW100-3	SW100-4
OFF	ON	OFF	OFF

LED100	LED101	LED102	LED103
Paper width sensor 4	Paper width sensor 3	Paper width sensor 2	Paper width sensor 1

Dip switch setting 4

SW100-1	SW100-2	SW100-3	SW100-4
ON	ON	OFF	OFF

LED100	LED101	LED102	LED103
Paper end sensor	Paper length sensor	Paper width sensor 6	Paper width sensor 5

Dip switch setting 5

SW100-1	SW100-2	SW100-3	SW100-4
OFF	OFF	ON	OFF

LED100	LED101	LED102	LED103
4th paper sensor	3rd paper sensor	2nd paper sensor	1st paper sensor

Dip switch setting 6

SW100-1	SW100-2	SW100-3	SW100-4
ON	OFF	ON	OFF

LED100	LED101	LED102	LED103
8th paper sensor	7th paper sensor	6th paper sensor	5th paper sensor

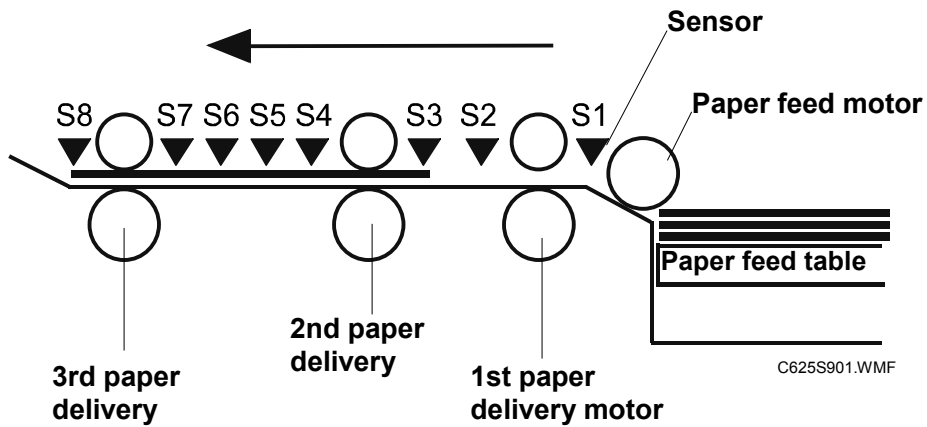

Service
Tables

Output check

1. Set the power on while you push the paper table-lifting switch and paper table-lowering switch.
2. LED100 to 103 all flash for 5 seconds.
3. Set the dipswitches as follows. Then examine the output for each of them.

Paper end solenoid and paper length solenoid

SW100-1	SW100-2	SW100-3	SW100-4
OFF	OFF	OFF	ON

Use the paper table-lifting switch and paper table lowering switch to do the solenoid tests, as shown below.

Paper table lifting switch - ON	Paper end solenoid - ON
	Paper length solenoid - ON
Paper table lowering switch - ON	Paper end solenoid - OFF
	Paper length solenoid - OFF

Paper table motor

SW100-1	SW100-2	SW100-3	SW100-4
ON	OFF	OFF	ON

Use the paper table lifting switch and paper table lowering switch to do the paper table motor tests, as shown below.

TABLE LIFTING SWITCH	PAPER TABLE MOTOR
ON	Table goes up
OFF	OFF
TABLE LOWERING SWITCH	PAPER TABLE MOTOR
ON	Table goes down
OFF	OFF

Paper feed motor

SW100-1	SW100-2	SW100-3	SW100-4
OFF	ON	OFF	ON

Use the paper table lifting switch to do the paper feed motor test, as shown below.

TABLE LIFTING SWITCH	Paper feed motor
ON	ON
OFF	OFF

1st paper delivery motor

SW100-1	SW100-2	SW100-3	SW100-4
ON	ON	OFF	ON

Use the paper table-lifting switch do the 1st paper delivery motor test, as shown below.

TABLE LIFTING SWITCH	1st paper delivery motor
ON	ON
OFF	OFF

2nd paper delivery motor

SW100-1	SW100-2	SW100-3	SW100-4
OFF	OFF	ON	ON

Use the paper table-lifting switch do the 2nd paper delivery motor test, as shown below.

TABLE LIFTING SWITCH	2nd paper delivery motor
ON	ON
OFF	OFF

3rd paper delivery motor

SW100-1	SW100-2	SW100-3	SW100-4
ON	OFF	ON	ON

Use the paper table-lifting switch do the 3rd paper delivery motor test, as shown below.

TABLE LIFTING SWITCH	3rd paper delivery motor
ON	ON
OFF	OFF



TO ENTER AND EXIT THE SP MODE - LCOT

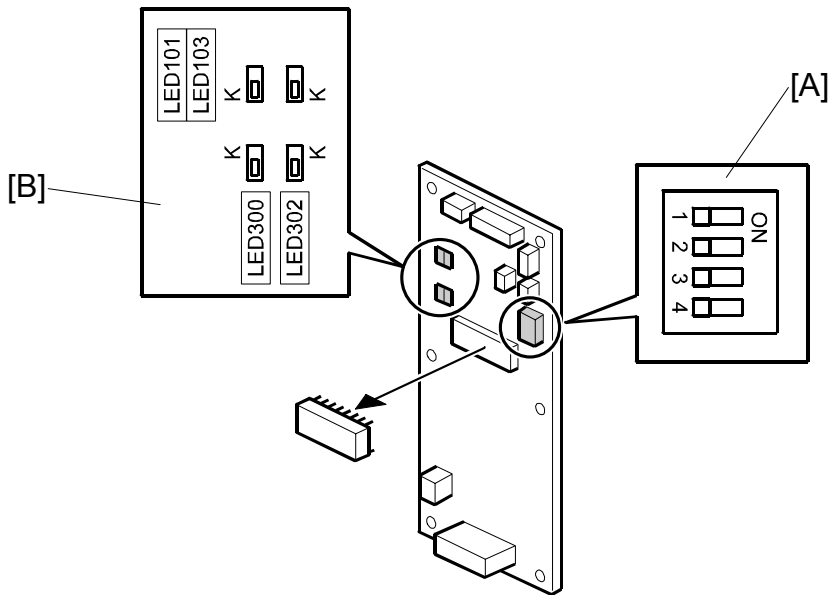

C625R34.WMF

1. Use dipswitch 300 [A] to operate the LCOT service programs. Use dipswitch 300 [A] to make adjustments.
2. Make sure the LCS works correctly before you go into the SP mode.
3. Write down the dipswitch positions [A] on the MPU before you go into the service program mode.
4. Set dipswitch 300 [A] back to the initial position after you complete the service mode.
5. Set the power off to go out of service program mode.

Input check

1. Set the power on (at the LCIT side) while you push the paper table-lifting switch and paper table-lowering switch at the LCOT side.
2. LED300 to 303 [B] flash for 5 seconds.
3. Set the dipswitches [A] as follows: Then examine the inputs on the LED [B].

Dip switch setting 1

SW300-1	SW300-2	SW300-3	SW300-4
OFF	OFF	OFF	ON

LED300	LED301	LED302	LED303
Paper amount sensor	Paper table lifting switch	Paper table lower limit sensor	Paper table upper limit sensor

Dip switch setting 2

SW300-1	SW300-2	SW300-3	SW300-4
OFF	OFF	ON	ON

LED300	LED301	LED302	LED303
	End plate release sensor		

Service Tables

Dip switch setting 3

SW300-1	SW300-2	SW300-3	SW300-4
OFF	ON	ON	ON

LED300	LED301	LED302	LED303
			Paper table lowering switch

Output check

1. Set the power on (at the LCIT side) while you push the paper table-lifting switch and paper table-lowering switch at the LCOT side.
2. LED300 to 303 flash for 5 seconds.
3. Set the dipswitches as follows: Then examine the output for each of them.

Paper table motor

SW300-1	SW300-2	SW300-3	SW300-4
ON	ON	ON	ON

Use the paper table lifting switch and paper table lowering switch to do the paper table motor tests, as shown below.

TABLE LIFTING SWITCH	PAPER TABLE MOTOR
ON	Table goes up
OFF	OFF
TABLE LOWERING SWITCH	PAPER TABLE MOTOR
ON	Table goes down
OFF	OFF

Adjustment

The quantity of downward movement of the tray

You can adjust the distance that the paper delivery table moves down. This will make paper delivery alignment better.

Adjustment range: 4.7 mm ~13.5 mm / 0.185" ~ 0.531" (50 msec~300 msec)

The default is an interval of 8.5 mm / 0.335" (140 msec).

You can adjust the interval of downward movement of the paper delivery table. This will depend on the paper delivery alignments.

SW300-1	SW300-2	SW300-3	SW300-4	Amount of drop down	DuraTION OF MOTION
ON	ON	ON	OFF	4.7 mm / 0.185"	50 msec
OFF	ON	ON	OFF	6.0 mm / 0.236"	80 msec
ON	OFF	ON	OFF	7.2 mm / 0.283"	110 msec
OFF	OFF	OFF	OFF	8.5 mm / 0.335"	140 msec
ON	OFF	OFF	OFF	9.8 mm / 0.386"	180 msec
OFF	ON	OFF	OFF	11.0 mm / 0.433"	220 msec
ON	ON	OFF	OFF	12.3 mm / 0.484"	260 msec
OFF	OFF	ON	OFF	13.5 mm / 0.531"	300 msec

You can adjust the distance between paper exit point and loading surface.
(☛4.3.4)

6. DETAILED SECTION DESCRIPTIONS

6.1 MECHANISM OVERVIEW

6.1.1 EXTERIOR – LCIT

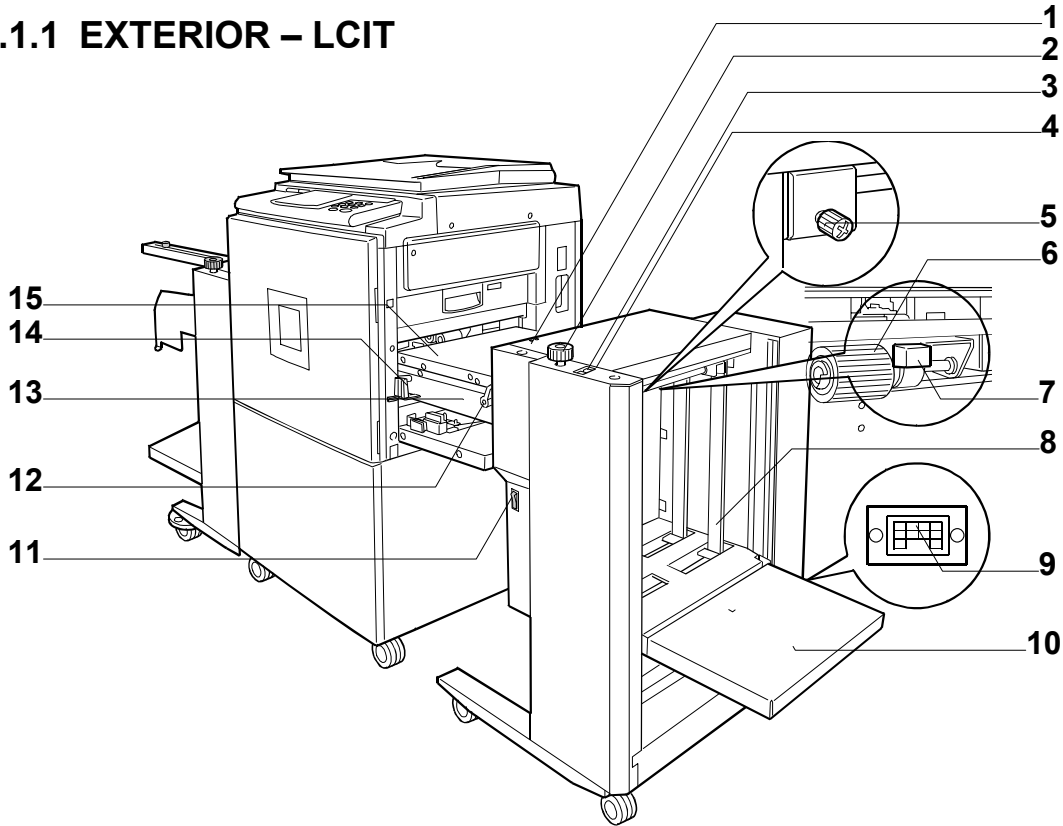

C625I903.WMF

- | | |
|--|---|
| <ol style="list-style-type: none"> 1. Indicators (LED): Indicate the LCIT status. 2. Side fence adjustment knob: Adjust the side fence according to the paper size. 3. Paper table lowering switch: Moves the paper feed table down. 4. Paper table lifting switch: Moves the paper feed table up and feeds a sheet of paper into the intermediate feed section. 5. Side fence screw: Locks or unlocks the side fences. 6. Paper feed roller: Feeds the paper 7. Separation pressure lever: Adjusts the contact pressure of the paper feed roller according to paper thickness. | <ol style="list-style-type: none"> 8. Side fence: Aligns paper to prevent paper skew. 9. Connection socket: Plug in the LCOT connection cord here. 10. Paper feed table: Load paper onto this table. 11. Main power switch: Turns the power on or off. 12. Upper cover release lever: Turn to unlock the cover. 13. Intermediate feed section: Feeds paper from the paper feed table to the duplicator. 14. LCIT release lever: Pull back to unlock the LCIT to detach it. 15. Intermediate upper cover: Open to remove misfed paper. |
|--|---|

Detailed Descriptions

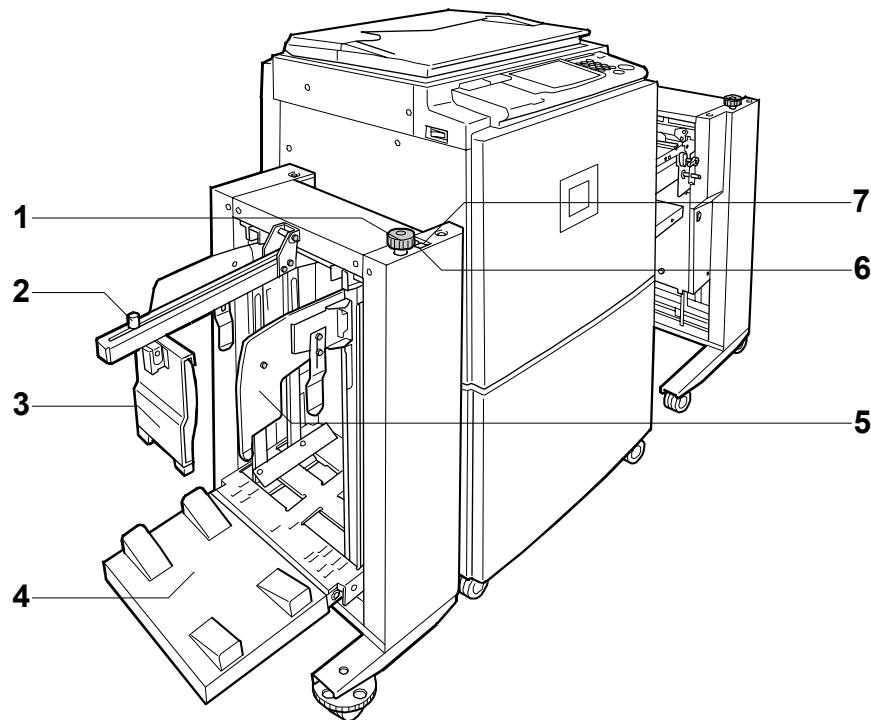
6.1.2 EXTERIOR - LCOT

C6251901.WMF

1. Side fence adjustment knob: Adjusts the side fences according to the paper size.
2. End plate screw: Use to lock or unlock the end plate.
3. End plate: Aligns the leading edge of prints.
4. Paper delivery table: Prints are delivered here.
5. Paper delivery side plate: Aligns the sides of prints.
6. Paper table lifting switch: Moves the paper delivery table up.
7. Paper table lowering switch: Moves the paper delivery table down.

6.1.3 ELECTRICAL COMPONENT LAYOUT

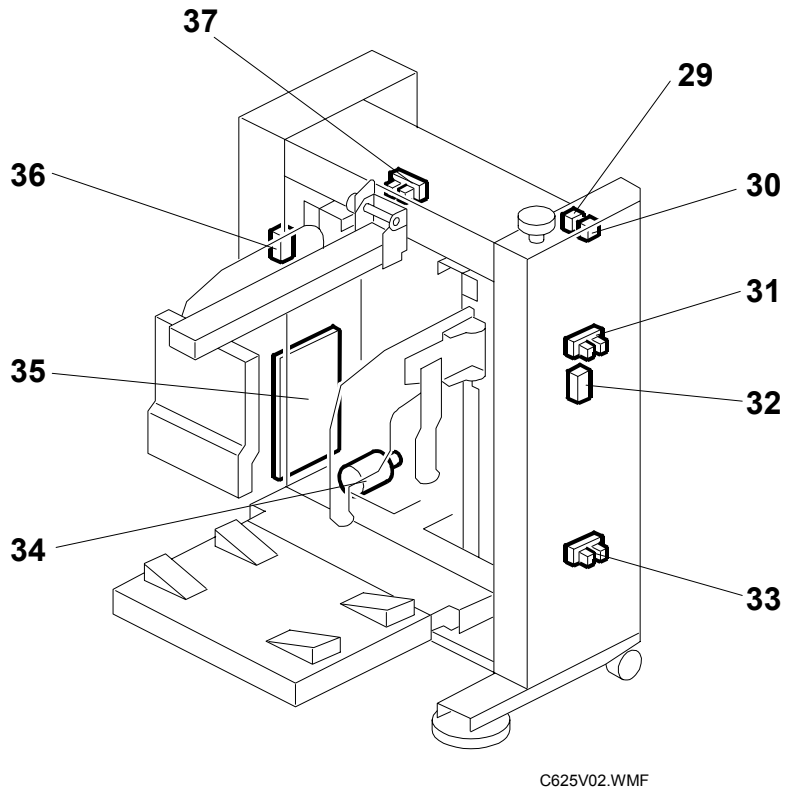
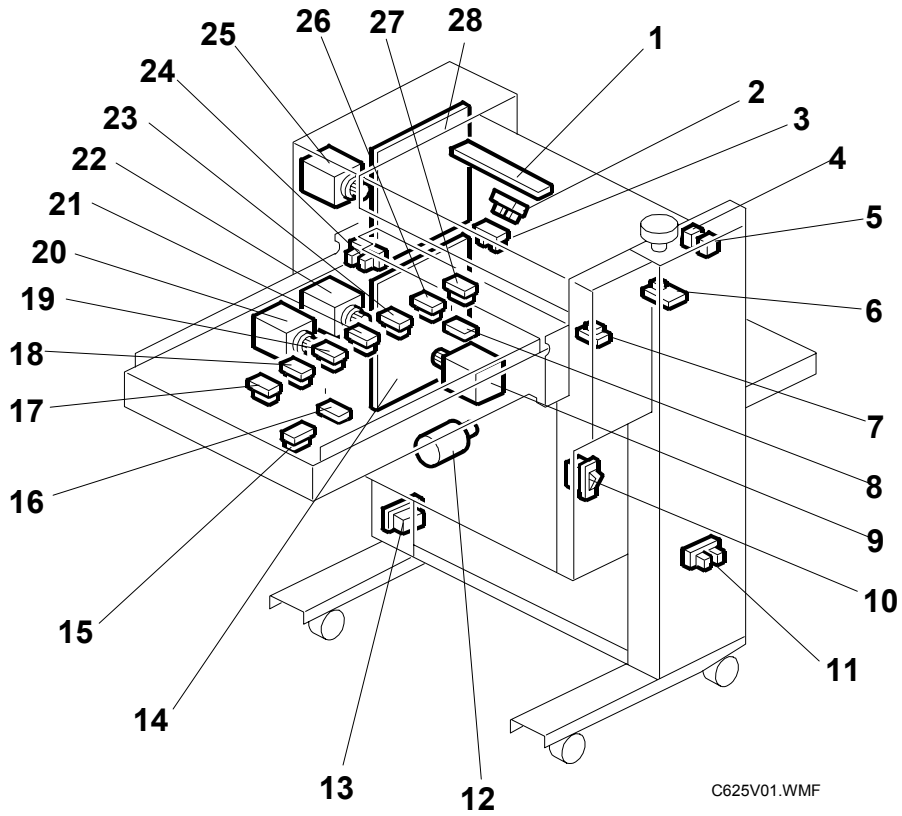

Detailed
Descriptions

Boards

No.	Component	Function
14	Power Supply Unit (PSU)	Provides dc power to the machine.
28	Main Processing Unit (MPU) - LCIT	Controls LCIT machine functions directly.
35	Main Processing Unit (MPU) - LCOT	Controls LCOT machine functions directly.

Motors

No.	Component	Function
9	2nd paper delivery motor	Feeds the paper at the intermediate feed section
12	Paper table motor - LCIT	Raises and lowers the paper feed tray
20	3rd paper delivery motor	Feeds the paper at the intermediate feed section
22	1st paper delivery motor	Feeds the paper at the intermediate feed section
25	Paper feed motor	Feeds the paper from the paper feed tray
34	Paper table motor - LCOT	Raises and lowers the paper eject tray

Switches

No.	Component	Function
4	Paper table lifting switch - LCIT	Lifts the paper feed tray
5	Paper table lowering switch - LCIT	Lowers the paper feed tray
10	Main power switch	Turns the power on or off
29	Paper table lifting switch - LCOT	Lifts the paper eject tray
30	Paper table lowering switch - LCOT	Lowers the paper eject tray

Solenoids

No.	Component	Function
16	Paper end solenoid	Opens and closes the paper end sensor inside the duplicator
8	Paper length solenoid	Opens and closes the paper length sensor inside the duplicator

Sensors

No.	Component	Function
1	Paper width detection sensors	Detects the width of the paper on the paper feed tray.
2	Paper table height sensor	Detects if the top of the paper stack on the paper table is at the paper feed height
3	Paper table upper limit sensor - LCIT	Detects when the paper feed tray is at its upper limit position.
6	Paper length sensor	Detects when long paper is on the paper feed tray.
7	Paper end sensor	Detects if paper is on the paper feed tray.
11	Paper table lower limit sensor - LCIT	Detects when the paper feed tray is at its lower limit position.
15	8th paper sensor	Detects if paper arrives correctly at the 8th position.
17	7th paper sensor	Detects if paper arrives correctly at the 7th position.
18	6th paper sensor	Detects if paper arrives correctly at the 6th position.
19	5th paper sensor	Detects if paper arrives correctly at the 5th position.
21	4th paper sensor	Detects if paper arrives correctly at the 4th position.
23	3rd paper sensor	Detects if paper arrives correctly at the 3rd position.
24	Intermediate upper cover release sensor	Detects if the intermediate upper cover is open.
26	2nd paper sensor	Detects if paper arrives correctly at the 2nd position.
27	1st paper sensor	Detects if paper arrives correctly at the 1st position.
31	Paper table upper limit sensor - LCOT	Detects when the paper eject tray is at its upper limit position.
32	Paper amount sensor - transmitter	Detects the volume of paper on the paper exit tray.
33	Paper table lower limit sensor - LCOT	Detects when the paper eject tray is at its lower limit position.
36	Paper amount sensor - receiver	Detects the volume of paper on the paper exit tray.
37	End plate release sensor	Detects if the end plate arm is positioned down.

Detailed
Descriptions**Others**

No.	Component	Function
13	Connection socket	Supplies power to the LCOT

6.2 PAPER FEED TABLE ON THE DUPLICATOR

Mechanism

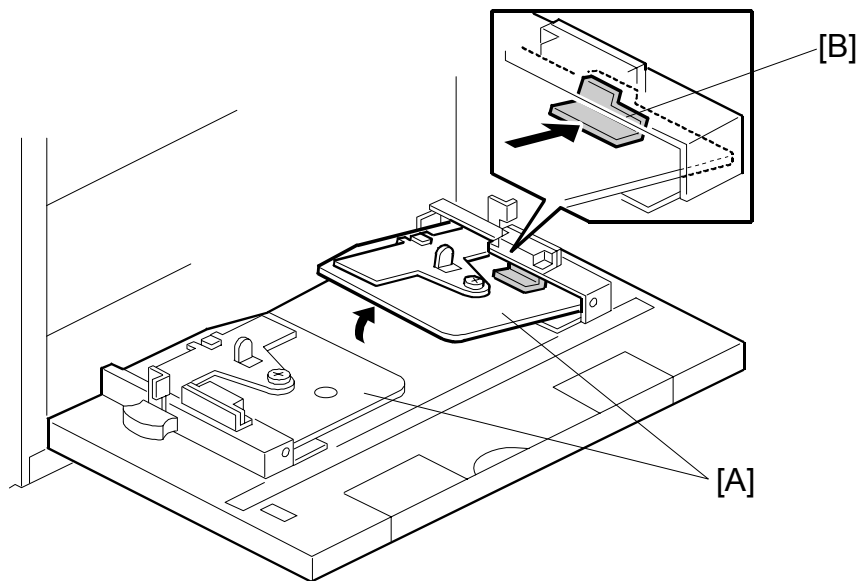

C625I03.WMF

When the LCIT will be connected to the duplicator, the paper feed side fences [A] on the duplicator must be folded down. However, the paper side fences [A] of the duplicator must be able to detect the paper size when they are folded down. This is because the paper size detectors on the LCIT are not yet implemented (☛ 6.3.1). To do this, attach the side fence guide [B] to the paper side fence [A] at the non-operation side. This allows the side fences to be closed fully for small-width paper. The side fence guide [B] prevents the paper feed side fence [A] from folding down completely.

NOTE: Because of the side fence guide [B], the paper feed side fence [A] rests above the paper feed table surface even when they are folded. Do not push it down forcefully.

6.3 PAPER FEED TABLE

6.3.1 PAPER SIZE AND PAPER END DETECTION

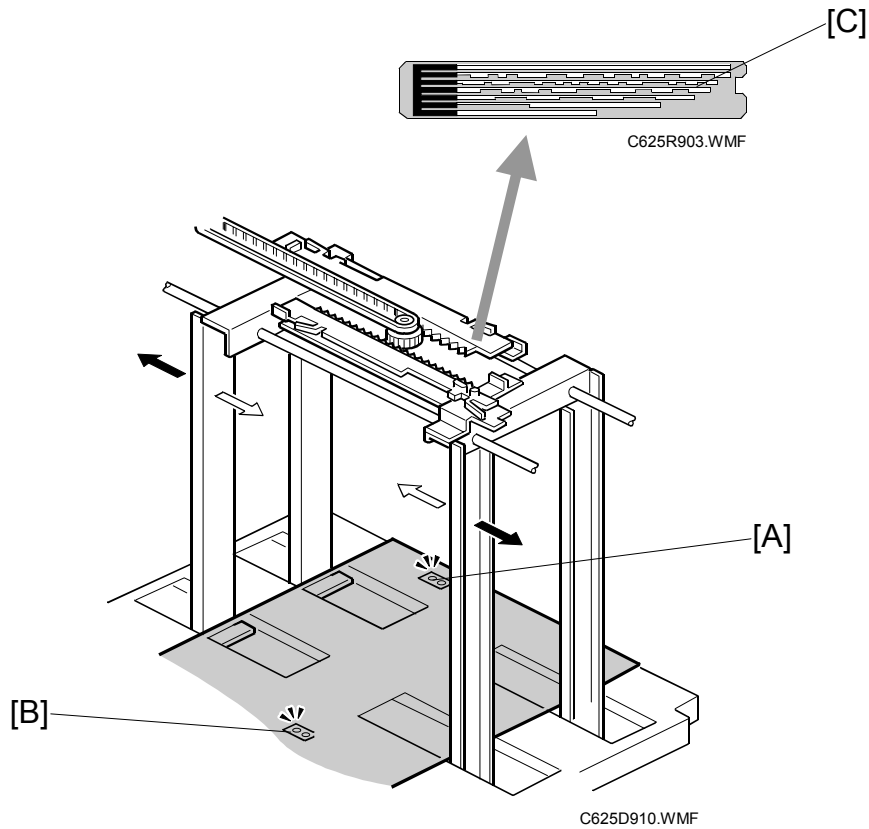

When paper is placed on the paper feed table, the paper end sensor [A], which is a reflective photosensor, is activated.

If B4 sized (or 8 1/2" x 14") paper or larger is set on the paper table, the paper length sensor [B] is activated.

The paper width detection sensor [C] is attached to the rack for the paper side fences. The paper width detection sensor [C] detects the position of the side fences. The paper width detection sensor is not implemented in current models; in future models, it will pass paper size information to the duplicator's operation panel. Paper width is detected by the duplicator (☛ 6.2).

Detailed
Descriptions

6.3.2 PAPER SIDE FENCE MECHANISM – LCIT

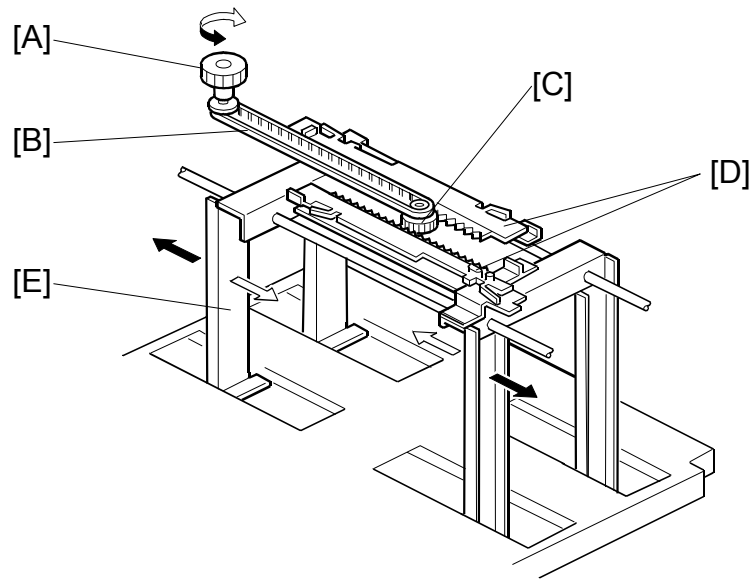

C625D911.WMF

Mechanism

Side fence adjustment knob [A]



Side fence adjustment belt [B]



Side fence adjustment pinion [C]



Side fence adjustment rack [D]



Side fence [E]

The left and right side fences move together due to a rack and pinion mechanism.

There are two side fence drive units (one at the top and one at the bottom). This prevents the paper feed side fences from twisting.

6.3.3 PAPER FEED TABLE DRIVE

Mechanism

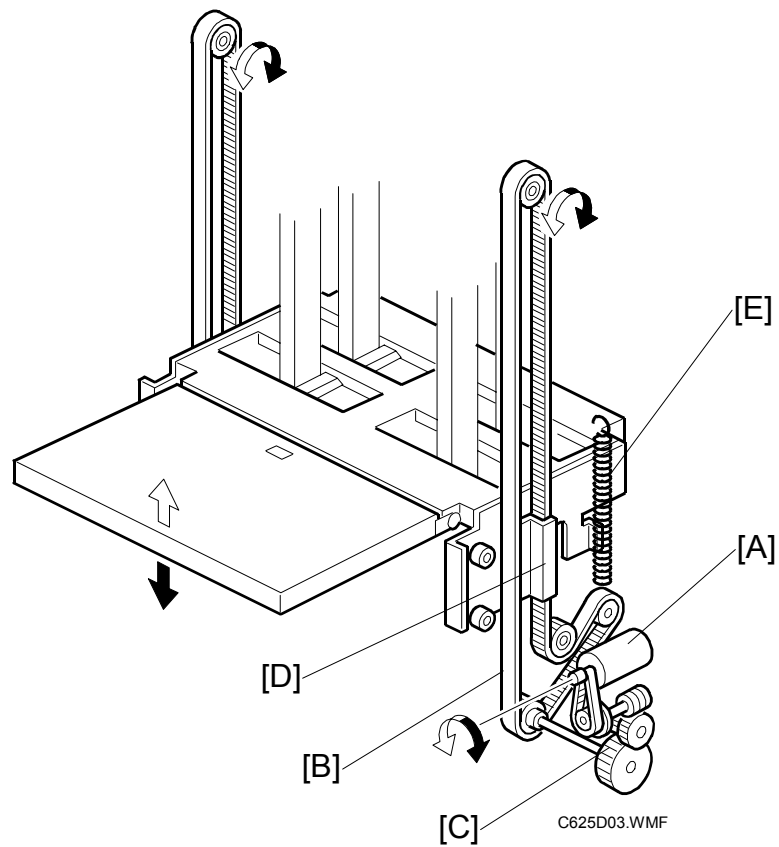

The paper table motor [A] (dc motor, with no other task), drives the paper table. When the motor turns, the paper table motor belt [B] turns through the gears [C]. The table motor belt bracket [D] fixes the belt, and the belt lifts and lowers the paper feed table. The table tension spring [E] prevents the paper table motor belt [B] from twisting.

6.3.4 PAPER FEED TABLE HEIGHT CONTROL

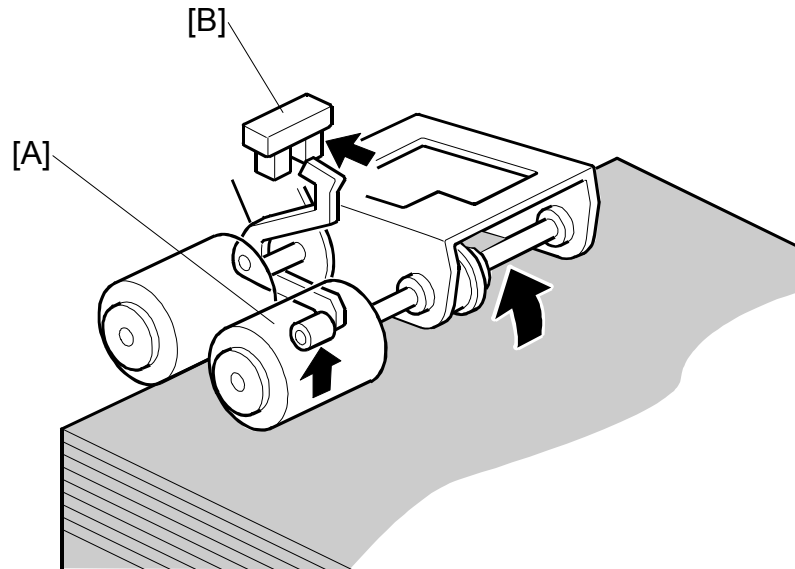

C625D907.WMF

When the paper feed table moves up, the top of the paper stack contacts the paper feed roller [A], lifting it up. Then, when the paper height sensor [B] is actuated, the paper table stops.

During a printing run, sheets are fed from the stack, and the paper feed roller lowers. When the paper height sensor is de-actuated, the paper table motor starts turning and lifts the paper table until the sensor is actuated again. In this way, the top of the paper stack remains at the same position during printing.

When paper runs out, the paper feed table lowers, until the paper table lower limit sensor (not shown) detects the lower limit position. This sensor is at the operation side of the machine.

6.4 PAPER FEED MECHANISM

6.4.1 PAPER FEED ROLLER MECHANISM

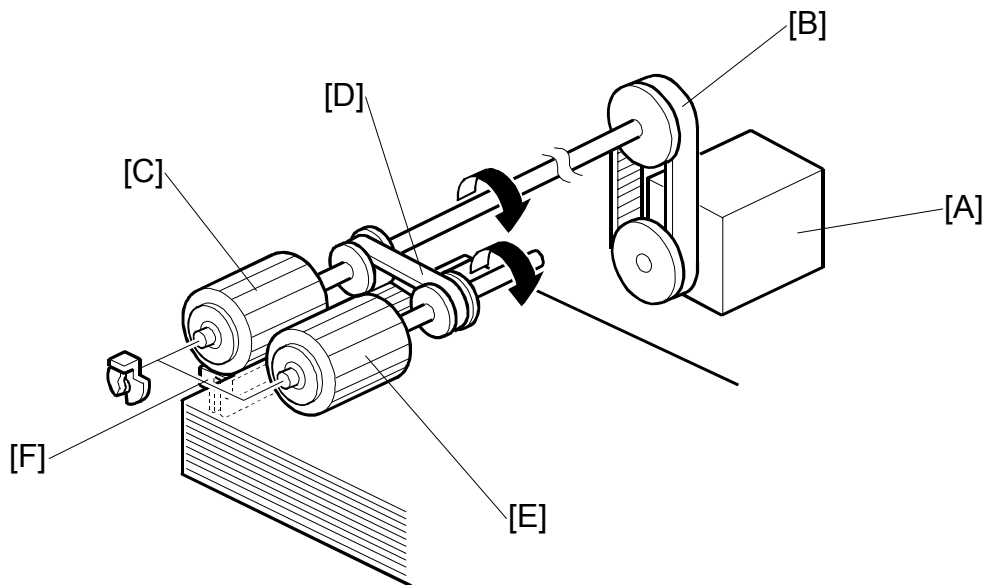

C625D902.WMF

Mechanism

Paper feed motor [A]



Paper feed motor belt [B]



Turns the paper separation roller [C]



Paper feed roller belt [D]



Turns the paper feed roller [E]

- NOTE:** 1) The machine uses a friction pad [F] and paper separation roller system. (👉 **CT**: Handling Paper – Paper Feed – Paper Feed Methods – Friction Pad)
- 2) When the rollers stop and paper is fed by the intermediate paper feed rollers, the one-way clutches in the paper feed and separation rollers ensure that these rollers do not resist paper feed.

6.4.2 PAPER FEED AND SEPARATION PRESSURE MECHANISM

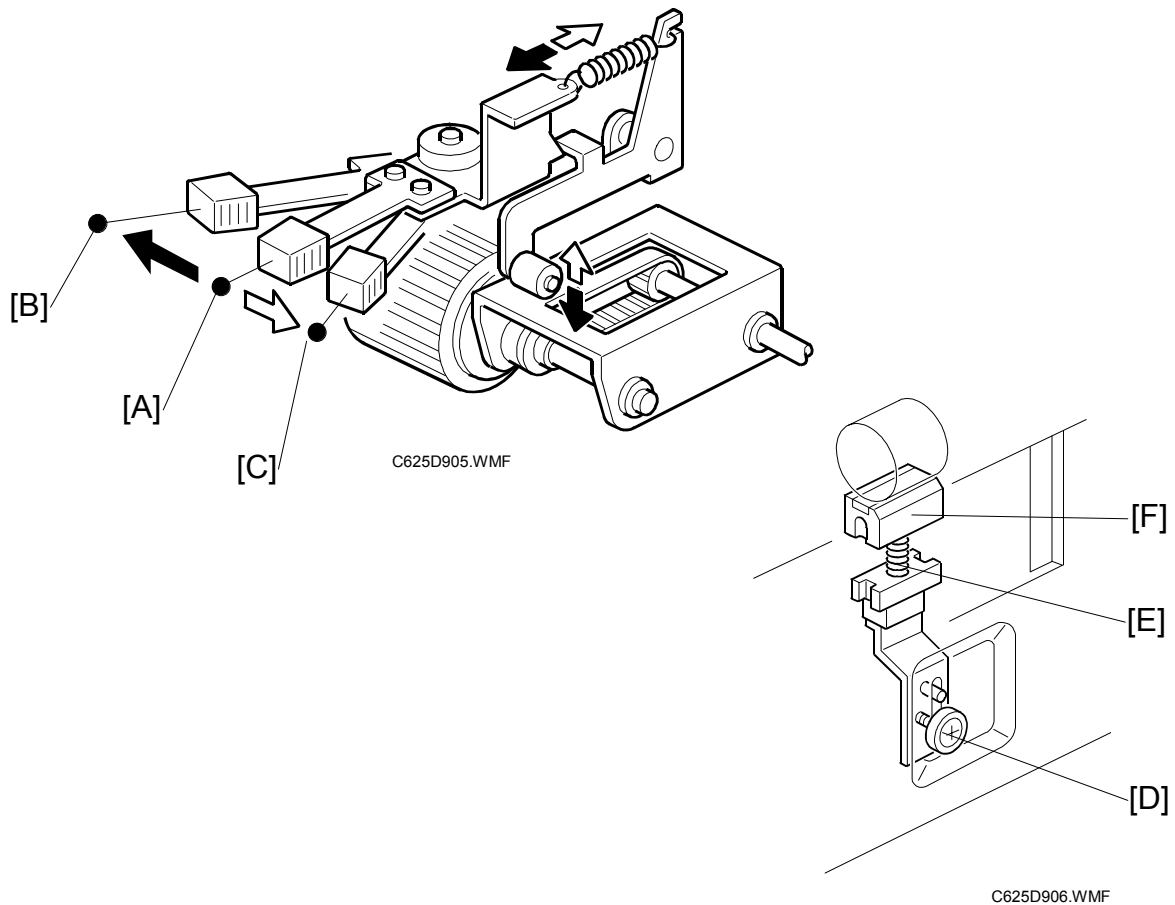

- [A]: Normal position
- [B]: Thick paper position
- [C]: Thin paper position

- The user can change the feed roller pressure by changing the position of the pressure adjustment lever [A].
- If paper feed jams frequently occur, the lever [A] should be moved to the left or the right to adjust the pressure.
- If non-feed or multi-sheet feed problems still occur, the paper separation pressure can also be adjusted.
- By loosening then moving the screw [D] up or down, the spring [E], which applies pressure to the friction pad block [F], moves up or down.

6.5 INTERMEDIATE FEED SECTION

6.5.1 OVERVIEW

Mechanism

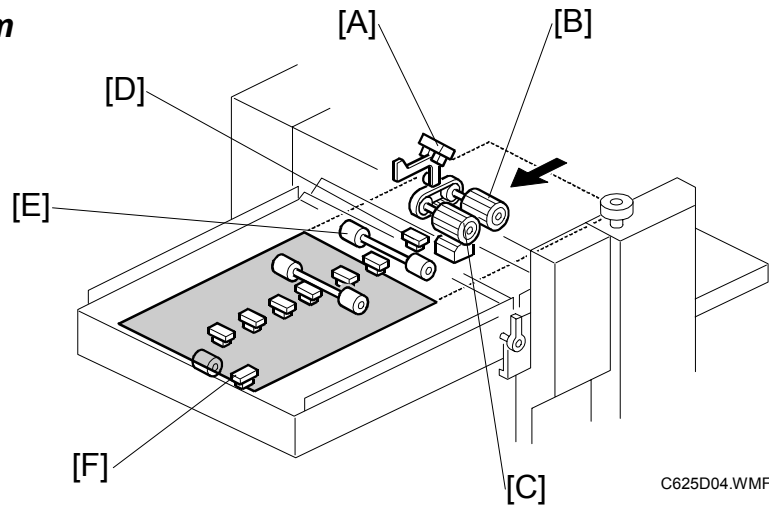

Paper table height sensor [A]



Paper feed motor (not shown; ➤ 6.4.1)



Paper feed roller [B] and paper separation roller [C]



Intermediate 1st paper sensor [D]



Intermediate 1st feed roller [E]



Intermediate 8th paper feed sensor [F]



Paper end and paper length solenoids

Procedure

When the paper table height sensor detects paper, the paper feed motor turns on and the paper feed and separation rollers rotate. When the paper reaches the intermediate 1st paper sensor, the intermediate feed rollers start rotation. When the paper is fed to the intermediate 8th paper feed sensor, which is the paper feed position for the duplicator, and the paper stops (➤ 6.5.3). At the same time, the paper end and length solenoids turn on and cover the paper end and length sensors in the duplicator (➤ 6.5.2).

6.5.2 TRANSFERRING PAPER DETECTION INFORMATION

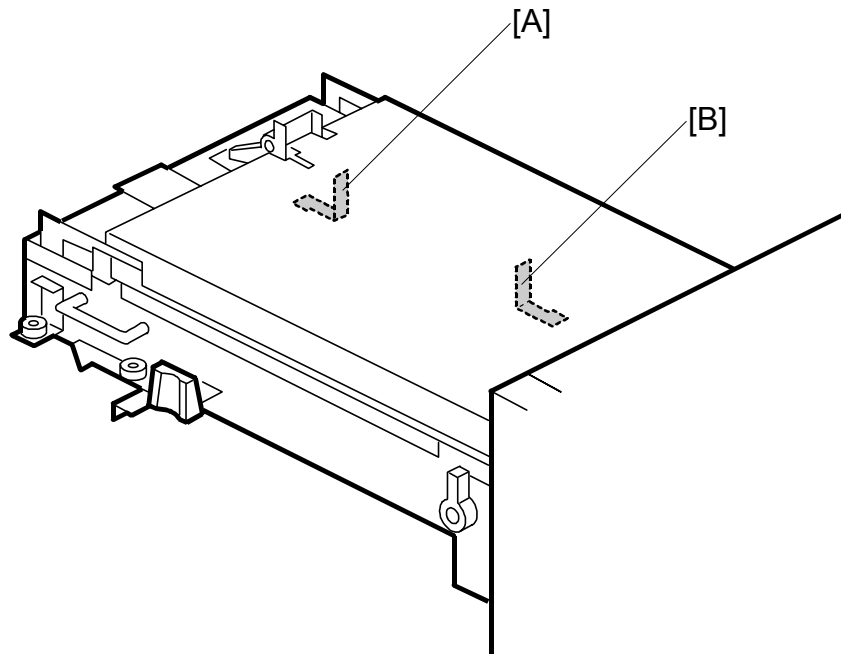

C625D908.WMF

Mechanism

Paper end sensor mylar [A]	Paper length sensor mylar [B]
Paper end sensor - LCIT ↓ Paper end solenoid ↓ Cover the paper end sensor - duplicator	Paper length sensor - LCIT ↓ Paper length solenoid ↓ Cover the paper length sensor - duplicator
After paper is set on the paper feed table for the LCIT, the paper end solenoid turns on and the end sensor mylar covers the paper end sensor on the duplicator after paper is fed to intermediate feed section.	If B4 sized (or 8 1/2" x 14") paper or larger is set on the paper feed table for the LCIT, the paper length solenoid turns on and the length sensor mylar covers the paper length sensor in the duplicator after pushing on the paper lifting switch.

6.5.3 INTERMEDIATE FEED MECHANISM

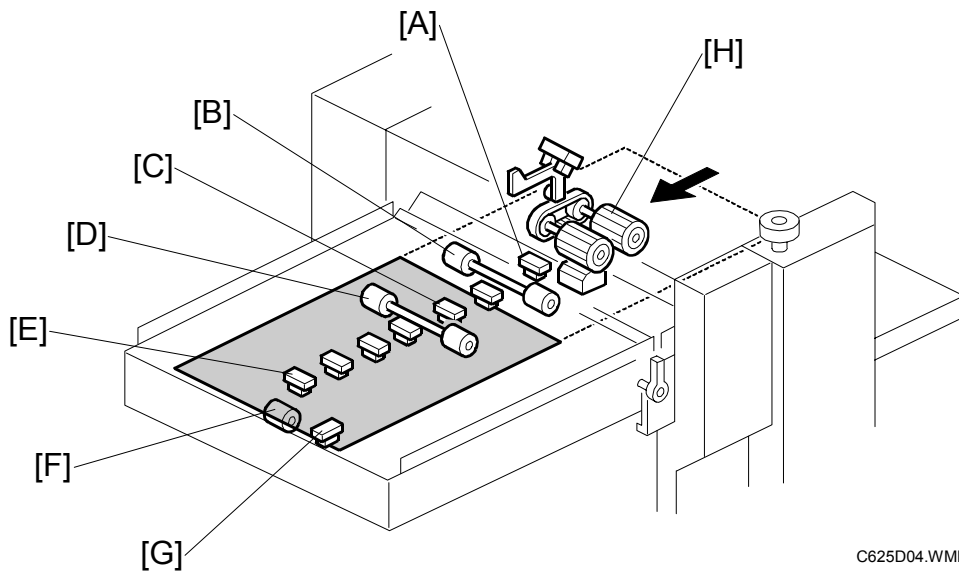

When the paper height sensor detects the paper, the paper goes into the intermediate feed section unless there is paper already in the intermediate feed section.

There are three lines of intermediate feed rollers, and 8 intermediate paper feed sensors.

The timing for to set on the sensors and the motors is controlled by the size of the paper.

The following timing is for A3 paper:

The paper feed roller [H] starts to rotate when the preceding paper passes through the intermediate 1st paper feed sensor [A], and the intermediate 1st feed roller [B].

When the 3rd sensor [C] detects the paper, then the 2nd roller [D] starts to rotate.

When the 7th sensor [E] detects the paper, then the 3rd roller [F] starts rotate.

When the paper reaches the 8th sensor, the paper waits for the duplicator to start.

Each of the intermediate feed rollers has its own motor and the speed of the paper feed motors is controlled to match the speed of the duplicator.

- Timing chart (☛6.7.1)

If the paper to precede passes through a sensor

6.6 PAPER DELIVERY TABLE

6.6.1 PAPER DELIVERY TABLE HEIGHT

Paper Delivery Table Drive Mechanism

(☛ 6.3.3)

6.6.2 PAPER AMOUNT DETECTION

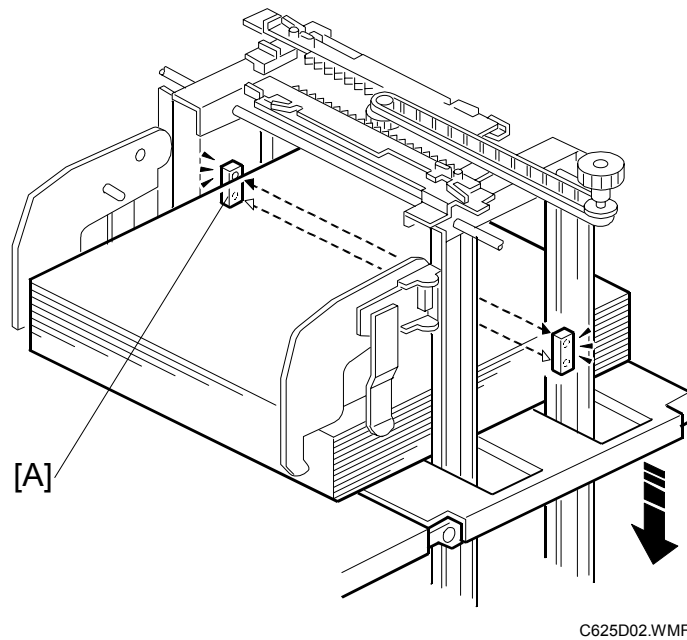

Mechanism

The LCOT automatically adjusts the height of the paper delivery table during printing, to keep the top of the stack at the same level. The paper amount sensor [A] contains two parts: receiver and transmitter. The receiver is at the operation side, and the transmitter is at the opposite side.

During printing, sheets are fed out to the top of the stack. When the paper amount sensor detects the top of the paper stack, the paper table moves down. The paper table moves down in 8.5mm (default) steps. In this way, the top of the paper stack remains at the same position during printing.

Timing chart (☛6.7.1)

6.6.3 PAPER SIDE FENCE MECHANISM - LCOT

(☛6.3.5)

6.7 TIMING CHART

6.7.1 PAPER FEED - LCIT

The timing of paper feed is different for each paper size.

Type	Paper size	Paper taking-in sensor ^{note1}	Interval between paper ^{note2}	Speed measurement section ^{note3}	Special control
1	DLT (SEF), A3 (SEF)	1st paper sensor	1 sensor	1st sensor - 2nd sensor	
2	B4 (SEF), LG (SEF)	2nd paper sensor	1 paper	2nd sensor - 3rd sensor	Note 4
3	A4 (LEF), B5 (LEF), LT (LEF)	3rd paper sensor	2 papers	3rd sensor - 5th sensor	
4	A4 (SEF), LT (SEF)	4th paper sensor	2 papers	4th sensor - 6th sensor	
5	B5 (SEF)	5th paper sensor	2 papers	5th sensor - 7th sensor	

- NOTE:**
- 1) When the preceding paper passes through the paper taking-in sensor, the next sheet of paper will be fed.
 - 2) The number of sensors between the paper while printing
 - 3) LCIT measures the feeding speed of the paper by checking the time when paper pass through the speed measurement section. Then it controls the speed of paper feed motors.
 - 4) While the intermediate 8th paper sensor is on (detects paper), the next sheet of paper stops at the intermediate 5th paper sensor. The paper is sent at 3/4 speed after the intermediate 8th sensor goes off.

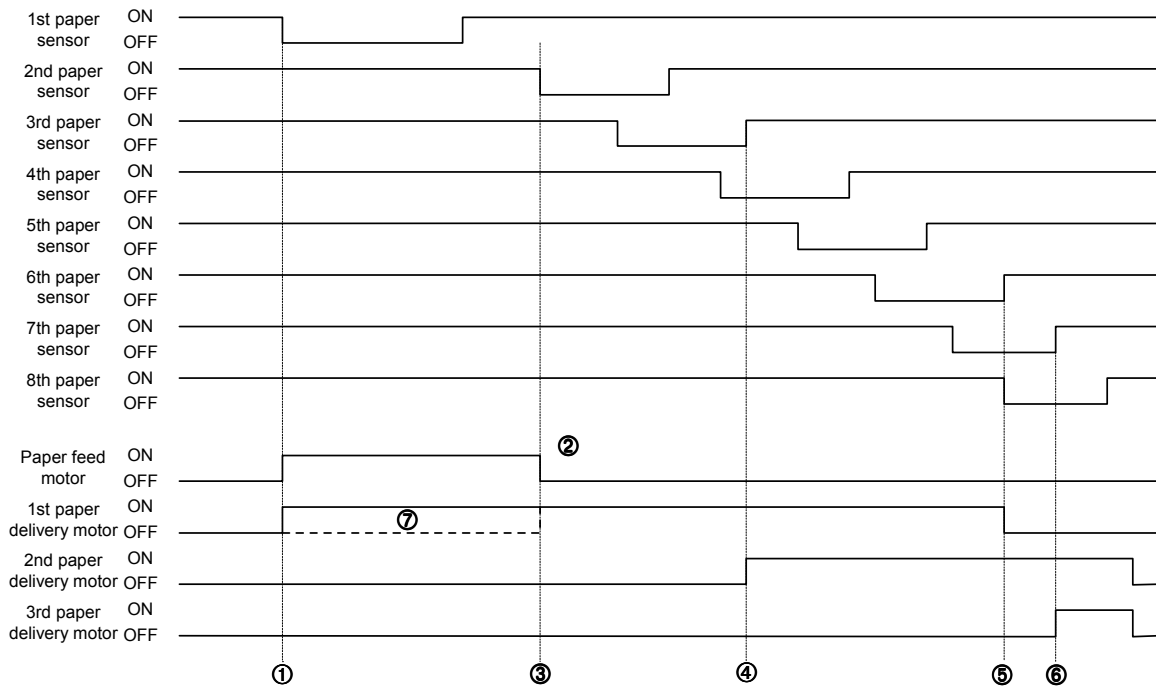
Type 1

C625D951.WMF

- ①: The paper taking-in sensor (for type 1, this is the intermediate 1st paper sensor) turns off and the paper feed motor and 1st paper delivery motor turn on.
- ②: The paper feed motor turns off automatically.
- ③: The intermediate 2nd paper sensor turns off and the 1st paper delivery motor turns on.
- ④: The paper passes the intermediate 3rd paper sensor, and the 2nd paper delivery motor turns on.
- ⑤: The paper passes the intermediate 6th sensor and the 1st paper delivery motor turns off.
- ⑥: The paper passes the intermediate 7th sensor and the 3rd paper delivery motor turns on.
- ⑦: The 1st paper delivery motor turns on at 500pps when the paper feed motor turns on, and continues to turn until point 3 on the timing chart.

6.7.2 PAPER DELIVERY TABLE

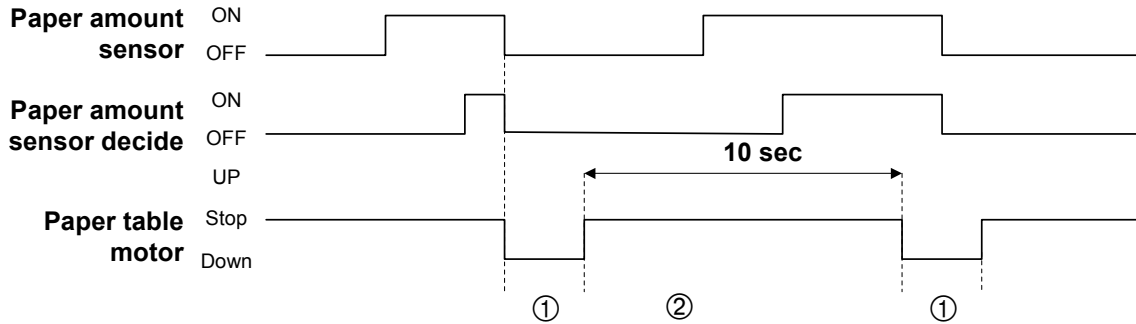

C625D950.WMF

- ①: The paper table motor turns on, because the paper amount sensor detected the top of the stack.
- ②: Ignore 10sec for detection of paper amount sensor so that it prevents the move downward too much for the misdetection.

Detailed Descriptions

7. POINT TO POINT DIAGRAM

7.1 LCIT (1)

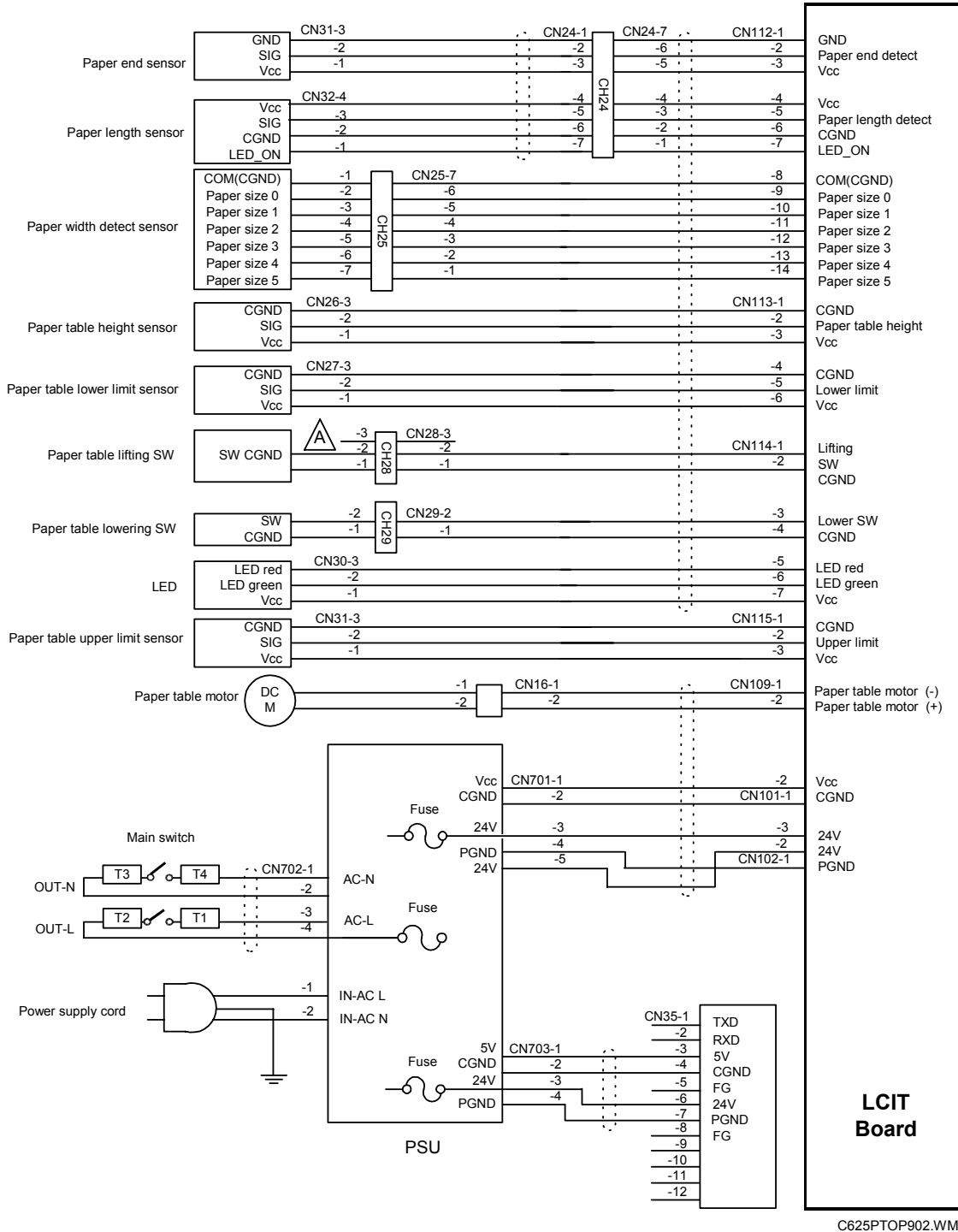

P-to-P

LCIT (2)

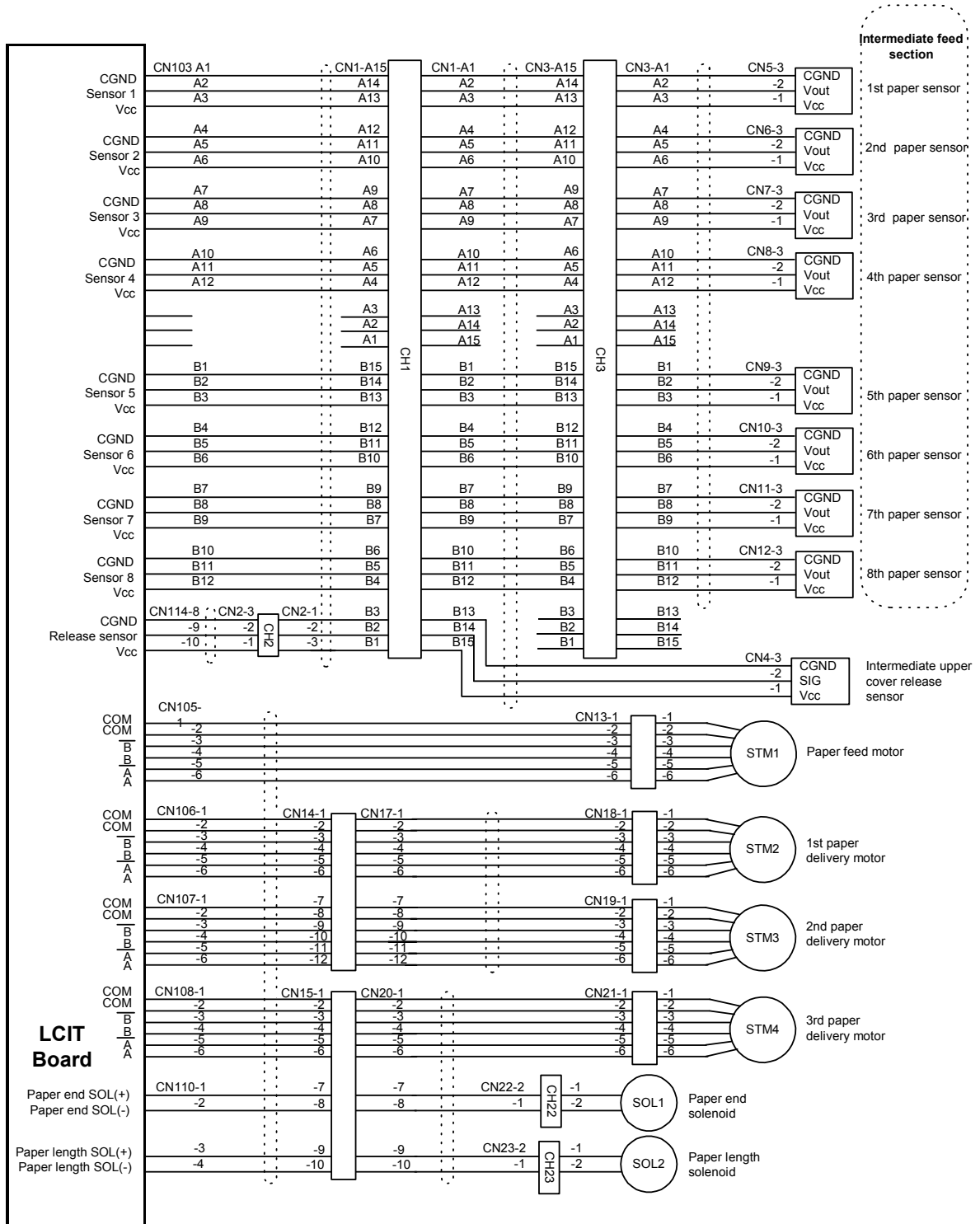

C625PTOP901.WMF

7.2 LCOT

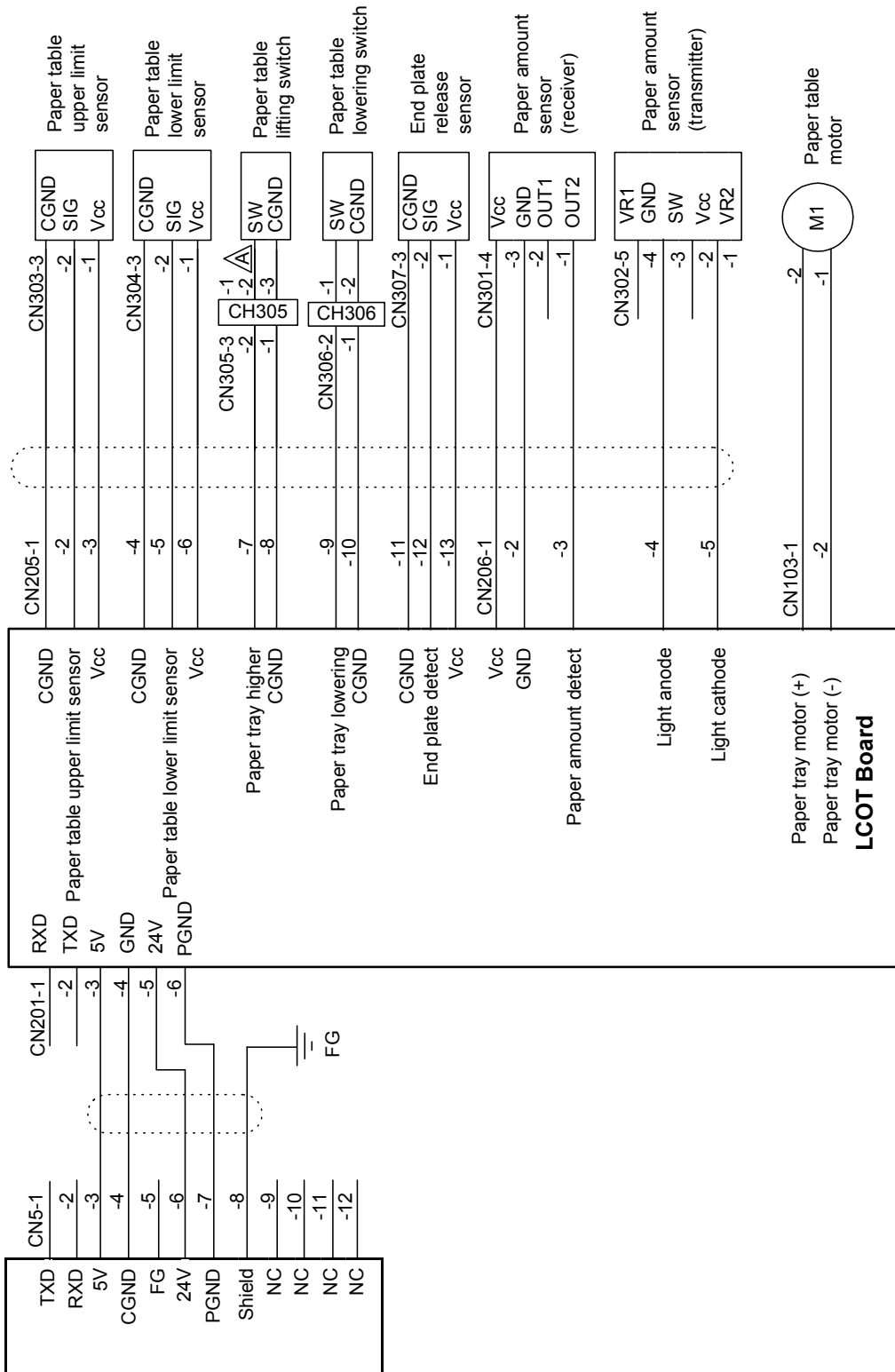

P-to-P

SPECIFICATIONS

1. GENERAL SPECIFICATIONS

Configuration:		There are two units: Large Capacity Input Tray (LCIT) Large Capacity Output Tray (LCOT) Only the LCIT can be used independently
Connectable Machines		C229, C233, C235, C239, C244, C593 Models
Paper input tray stack capacity		3000 sheets (80g/m ² or 20lb) Can load to a maximum stack height of 320mm/12.5"
Paper output tray stack capacity		3000 sheets (80g/m ² or 20lb) Can load to a maximum stack height of 345mm/13.5"
Print Paper Size:	LCIT:	Maximum: 297 x 432 mm / 11.6" x 17.0" Note: 325 x 447 mm / 12.7" x 17.5" possible when image position adjustment is not used. Minimum: 128 x 182 mm / 5.1" x 7.1"
	LCOT:	Maximum: 297 x 432 mm / 11.6" x 17.0" Note: 325 x 447 mm / 12.7" x 17.5" possible when image position adjustment is not used. Minimum: 128 x 182 mm / 5.1" x 7.1" Minimum: 70 x 148 mm / 2.8" x 5.9" possible when paper feed table of duplicator is used.
Print Paper Weight:		47.1 – 209.3 g/m ² , 12.5 – 55.61 lb.
Printing Speed:		To agree with the machine specification 60, 75, 90, 105, 120 sheets/minute (5 steps)
Power Source:		120 V, 3A, 60 Hz 220 - 240 V, 2A, 50/60 Hz
Power Consumption:		Operation: 88W or less Standby: 25W or less
Noise Emission		Sound Power Level Standby: Not above 45 dB(A) Copying 60 rpm: Not above 78 dB(A) Copying 90 rpm: Not above 80 dB(A) Copying 120 rpm: Not above 81 dB(A) Operating Position Sound Power Level Copying 60 rpm: 69db Copying 90 rpm: 70db Copying 120 rpm: 71db These were measured in accordance with ISO 7779.
Dimensions (W x D x H)		LCIT: Installation: 968 x 545 x 778 mm (38.1" x 21.4" x 30.6") Individual: 466 x 545 x 778 mm (18.3" x 21.4" x 30.6") LCOT: Installation: 560 x 512 x 778 mm (22" x 20.1" x 30.6") Individual: 560 x 512 x 778 mm (22" x 20.1" x 30.6")
Weight:		LCIT: Less than 45kg (99lb) LCOT: Less than 30kg (66lb)

Do not install in locations that are in direct sunlight.